

# TX-21AD3F Service Manual

Safety

Specifications

Parts List

Service  
Information

Adjustments

Self Check

Service Hints

Mechanical  
View

Disassembly

Location of  
Controls

Waveforms

Block Diagrams

Schematic Diagrams

PCB Views

## Service Support

Service and repair of this product is supported by Panasonic's LUCI interface.

This interface provides a link between the TV and a standard PC to allow a number of diagnostic and control functions to be performed.

For more details contact your local Panasonic company.

  
BACK

EXIT

Video / Audio

Control



BACK

B - PCB

E - PCB

Y - PCB



BACK

B - Schematic

E - Schematic

P - Schematic

Y - Schematic



BACK

# Service Manual

## Colour Television TX-21AD3F

### EURO-2M Chassis



#### Specifications

<b>Power Source :</b>	220 - 240 V AC, 50Hz
<b>Power Consumption :</b>	75W
<b>Aerial Impedance :</b>	75Ω unbalanced, Coaxial Type
<b>Receiving System :</b>	PAL B, G, H PAL - 60 SECAM B, G L, L' MNTSC, NTSC (AV Only)
<b>Receiving Channels :</b>	VHF E2 - E12 VHF H1 - H2 (ITALY) VHF R1 - R2 VHF R6 - R12 UHF E21 - E69 CATV (S01 - S05) CATV S11 - S20 (U1 - U10)
<b>Intermediate Frequency :</b>	Video 38.9MHz, 34MHz Sound 33.16MHz, 33.4MHz, 32.4MHz, 33.05MHz 40.4MHz, 32.9MHz
<b>Colour</b>	34.47MHz, 34.5MH, 34.65MHz
<b>Video / Audio Terminals :</b>	
AV1 IN	Video (21 pin) 1V p-p 75Ω Audio (21 pin) 500mV rms 10kΩ RGB (21 pin)
AV1 OUT	Video (21 pin) 1V p-p 75Ω Audio (21 pin) 500mV rms 1kΩ
AV2 IN	Video (21 pin) 1V p-p 75Ω Audio (21 pin) 500mV rms 10 kΩ S-Video IN Y : 1V p-p 75Ω (21 pin) C : 0.3V p-p 75Ω
AV2 OUT	Video (21 pin) 1V p-p 75Ω Audio (21 pin) 500mV rms 1kΩ
AV3 IN	Audio (RCA x 2) 500mV rms 10kΩ Video (RCA x 1) 1V p-p 75Ω
<b>High Voltage :</b>	27kV ± 1kV at zero beam current
<b>Picture Tube :</b>	A51ECQ51X01 51 cm
<b>Visible screen size:</b>	90° deflection
<b>Audio Output :</b>	
Internal Speaker	2 x 20W (Music Power) 8Ω Impedance
Headphones	8Ω Impedance
<b>Accessories supplied :</b>	Remote Control 2 x R6 (UM3) Batteries
<b>Dimensions :</b>	Height : 465mm Width : 558mm Depth : 495mm
<b>Net Weight</b>	23kg

Specifications are subject to change without notice.  
Weight and dimensions shown are approximate.

#### Technische Daten

<b>Netzspannung :</b>	220 - 240 V AC, 50Hz
<b>Leistungsaufnahme :</b>	75W
<b>Antennenimpedanz :</b>	75Ω asymmetrisch, Koaxial - Typ
<b>Empfangssystem :</b>	PAL B, G, H PAL - 60 SECAM B, G L, L' MNTSC, NTSC (nur AV Eingang)
<b>Empfangsbereiche :</b>	VHF E2 - E2 VHF H1 - H2 (ITALY) VHF R1 - R2 VHF R6 - R12 UHF E21 - E69 CATV (S01 - S05) CATV S11 - S20 (U1 - U10)
<b>Zwischenfrequenz :</b>	Video 38.9MHz, 34MHz Sound 33.16MHz, 33.4MHz, 32.4MHz, 33.05MHz 40.4MHz, 32.9MHz
<b>Colour</b>	34.47MHz, 34.5MH, 34.65MHz
<b>Video / Audio Anschlüsse :</b>	
AV1 EINGANG	Video (21 pin) 1V p-p 75Ω Audio (21 pin) 500mV rms 10kΩ RGB (21 pin)
AV1 AUSGANG	Video (21 pin) 1V p-p 75Ω Audio (21 pin) 500mV rms 1kΩ
AV2 EINGANG	Video (21 pin) 1V p-p 75Ω Audio (21 pin) 500mV rms 10 kΩ S-Video IN Y : 1V p-p 75Ω (21 pin) C : 0.3V p-p 75Ω
AV2 AUSGANG	Video (21 pin) 1V p-p 75Ω Audio (21 pin) 500mV rms 1kΩ
AV3 EINGANG	Audio (RCA x 2) 500mV rms 10kΩ Video (RCA x 1) 1V p-p 75Ω
<b>Hochspannung :</b>	27kV ± 1kV bei Nullstrahlstrom
<b>Bildrohre :</b>	A51ECQ51X01 51 cm
<b>Visuelle Diagonale :</b>	90° Ablenkung
<b>Ton Ausgangsleistung :</b>	
Einbaulautsprecher	2 x 20W (Musikleistung) 8Ω Impedanz
Kopfhörer	8Ω Impedanz
<b>Mitgel. Zubehör</b>	Fernbedienung 2 x R6 (UM3) Batterien
<b>Abmessungen :</b>	Höhe : 465mm Breite : 558mm Tiefe : 495mm
<b>Gewicht</b>	23kg

Änderungen der technischen Daten vorbehalten.  
Gewichte und Abmessungen sind Näherungsangaben.

# Panasonic

## CONTENTS

SAFETY PRECAUTIONS .....
LOCATION OF CONTROLS .....
SERVICE HINTS .....
ADJUSTMENTS .....
SELF CHECK .....
WAVEFORM PATTERN TABLE .....
BLOCK DIAGRAM .....
PARTS LOCATION .....
REPLACEMENT PARTS LIST .....
CONDUCTOR VIEWS .....
SCHEMATIC DIAGRAMS .....

## SAFETY PRECAUTIONS

### General Guide Lines

1. It is advisable to insert an isolation transformer in the AC supply before servicing a hot chassis.
2. When servicing, observe the original lead dress in the high voltage circuits. If a short circuit is found, replace all parts which have been overheated or damaged by the short circuit.
3. After servicing, see that all the protective devices such as insulation barriers, insulation papers, shields and isolation R—C combinations are correctly installed.
4. When the receiver is not being used for a long period of time, unplug the power cord from the AC outlet.
5. Potentials as high as 28kV are present when this receiver is in operation. Operation of the receiver without the rear cover involves the danger of a shock hazard from the receiver power supply. Servicing should not be attempted by anyone who is not familiar with the precautions necessary when working on high voltage equipment. Always discharge the anode of the picture to the chassis before handling the tube.
6. After servicing make the following leakage current checks to prevent the customer from being exposed to shock hazards.

## LEAKAGE CURRENT COLD CHECK

1. Unplug the AC cord and connect a jumper between the two prongs of the plug.
2. Turn on the receiver's power switch.
3. Measure the resistance value with an ohmmeter, between the jumpered AC plug and each exposed metallic cabinet part on the receiver, such as screw heads, aerials, connectors, control shafts etc. When the exposed metallic part has a return path to the chassis the reading should be between 4M ohm and 20M ohm. When the exposed metal does not have a return path to the chassis the reading must be infinite.

## INHALT

SICHERHEITSVORKEHRUNGEN .....
LAGE DER EINSTELLREGLER .....
WARTUNGSHINWEISE .....
JUSTIERUNGEN .....
SELBSTDIAGNOSE .....
SIGNAL TABELLE .....
SCHALTBILD BLOCK .....
EXPLOSIONSZEICHNUNG .....
ERSATZTEILLISTE .....
ANSICHT DER LEITERBAHNEN .....
SCHALTBILD SCHEMA .....

## SICHERHEITSVORKEHRUNGEN

### Allgemeine Richtlinien

1. Es ist empfehlenswert einen Trenntransformator in die Stromversorgung zu schalten, bevor Reparaturen an einem Gerät vorgenommen werden, dessen Chassis unter Spannung steht.
2. Bei der Durchführung von Servicearbeiten dürfen die ursprünglichen Kabelanschlüsse nicht vertauscht werden. Dies gilt insbesondere für die Anschlüsse im Hochspannungsteil. Hat sich ein Kurzschluß ereignet, dann sind alle Teile, an denen Spuren von Überhitzung sichtbar sind, auszuwechseln.
3. Nach Beenden der Servicearbeiten ist sicherzustellen, daß alle Sicherheitsvorrichtungen, wie Isolationsstege, Isolationspapiere, Abschirmungen und Isolations—R/C— Glieder wieder richtig eingesetzt sind.
4. Wenn der Fernseher während längerer Zeit nicht in Betrieb gesetzt wird, sollte der Netzstecker aus der Netzsteckdose gezogen werden.
5. Im Betrieb sind Spannungen bis zu 28kV in diesem Gerät vorhanden. Die Inbetriebnahme des Fernsehers ohne aufgesetzte Rückwand bringt die Gefahr eines elektrischen Schlages von der Fernseher — Stromversorgung mit sich. Servicearbeiten sollten daher auch nie durch Personen versucht werden, die nicht in vollem Umfang mit den Sicherheitsvorkehrungen beim Umgang mit Hochspannungsgeräten vertraut sind. Vor der Handhabung mit der Bildröhre ist die Anode der Bildröhre immer an dem Empfängerchassis zu entladen.
6. Nach Beenden der Servicearbeiten sind die folgenden Kriechstrom—Prüfungen durchzuführen, um den Kunden vor der Gefahr eines elektrischen Schlages zu schützen.

## MESSUNG DES ISOLATIONSWIDERSTANDES IM ABGESCHALTETEN ZUSTAND

1. Den Netzstecker aus der Netzsteckdose ziehen und die beiden Steckerstifte kurzschließen.
2. Den Geräteschalter des Fernsehgerätes einschalten.
3. Mit einem Ohmmeter den Widerstandswert zwischen dem überbrückten Netzstecker und jedem zugänglichen Metallteil am Gehäuse des Fernsehgerätes, wie Schraubenköpfe, Antennen, Achsen der Regler, Grifffassungen usw messen. Wenn ein zugängliches Metallteil keine Rückleitung zum Chassis hat, muß die Anzeige unendlich betragen.

## LEAKAGE CURRENT HOT CHECK

1. Plug the AC cord directly into the AC outlet. Do not use an isolation transformer for this check.
2. Connect a 2kΩ 10W resistor in series with an exposed metallic part on the receiver and an earth such as a water pipe.
3. Use an AC voltmeter with high impedance to measure the potential across the resistor.
4. Check each exposed Metallic part and check the voltage at each point.
5. Reverse the AC plug at the outlet and repeat each of the above measurements.
6. The potential at any point should not exceed 1.4 Vrms. In case a measurement is outside the limits specified, there is a possibility of a shock hazard, and the receiver should be repaired and rechecked before it is returned to the customer.

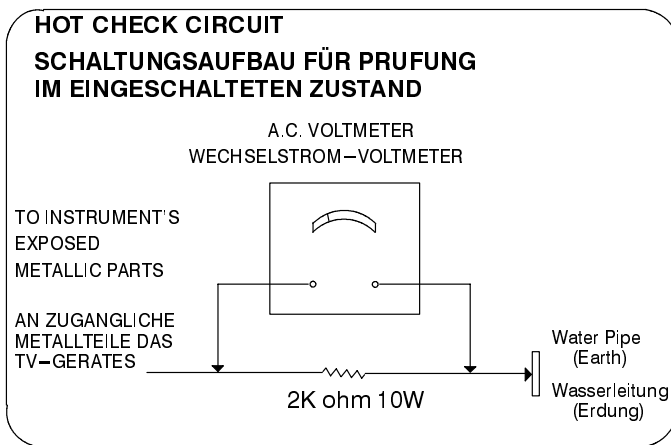

Fig.1  
Abb.1

## X-RADIATION WARNING

1. The potential sources of X-Radiation in TV sets are the high voltage section and the picture tube.
2. When using a picture tube test jig for service ensure that the jig is capable of handling 28kV without causing X-Radiation.

**NOTE :** It is important to use an accurate periodically calibrated high voltage meter

1. Set the brightness to minimum.
2. Measure the high voltage. The meter should indicate 27kV ± 1kV if the meter indication is out of tolerance, immediate service and correction is required to prevent the possibility of premature component failure.
3. To prevent any X-Radiation possibility, it is essential to use the specified tube.

## MESSUNG DES KRIECHSTROMS IM EINGESCHALTETEN ZUSTAND

1. Den Netzstecker direkt in eine Netsteckdose stecken. Für diese Messung keinen Trenntransformator verwenden.
2. Einen 2k Ω / 10W-Widerstand in Serie mit einem von außen zugänglichen Metallteil am Fernsehgerät und einer guten, Erdung z.B Wasserleitung, anschließen.
3. Ein Wechselstrom-Voltmeter mit einem Meßbereich von 1000 Ohm.Volt oder größer verwenden, um die Spannung über den Widerstand zu messen.
4. Jedes zugängliche Metallteil prüfen, und an jedem Punkt die Spannung messen.
5. Den Netzstecker umgekehrt in die Steckdose stecken und jede der obigen Messungen wiederholen.
6. Die Spannung darf an keinem der Punkte 1.4V eff. überschreiten. Wird dieser Wert nicht eingehalten, besteht die Gefahr eines elektrischen Schlages, und das Fernsehgerät sollte daher repariert und nachgeprüft werden, bevor es an den Kunden zurückgegeben wird.

## RÖNTGENSTRAHLUNG

### ACHTUNG :

1. Potentielle Quellen von Röntgenstrahlung in Fernsehgeräten sind das Hochspannungsteil und die Bildröhre.
2. Bei Verwendung eines Bildröhren-Prüfgerätes für den Service ist sicherzustellen, daß es für die Belastung von 28kV geeignet ist, ohne daß eine Röntgenstrahlung verursacht wird.

**ANMERKUNG :** Es ist wichtig, daß ein präzises, regelmäßig geprüftes Voltmeter verwendet wird.

1. Helligkeit auf Minimum stellen.
2. Die Hochspannung messen. Die Anzeige des Instrumentes sollte 27kV ± 1kV betragen. Falls die Anzeige diese Toleranzgrenzen überschreitet, ist die sofortige Behebung nötig, um die Möglichkeit vorzeitigen Komponentenausfalls zu verhüten.
3. Um die Möglichkeit von Röntgenstrahlung zu begrenzen, ist es wichtig, daß nur die vorgeschriebene Bildröhre verwendet wird.

## LOCATION OF CONTROLS

## LAGE DER EINSTELLREGLER

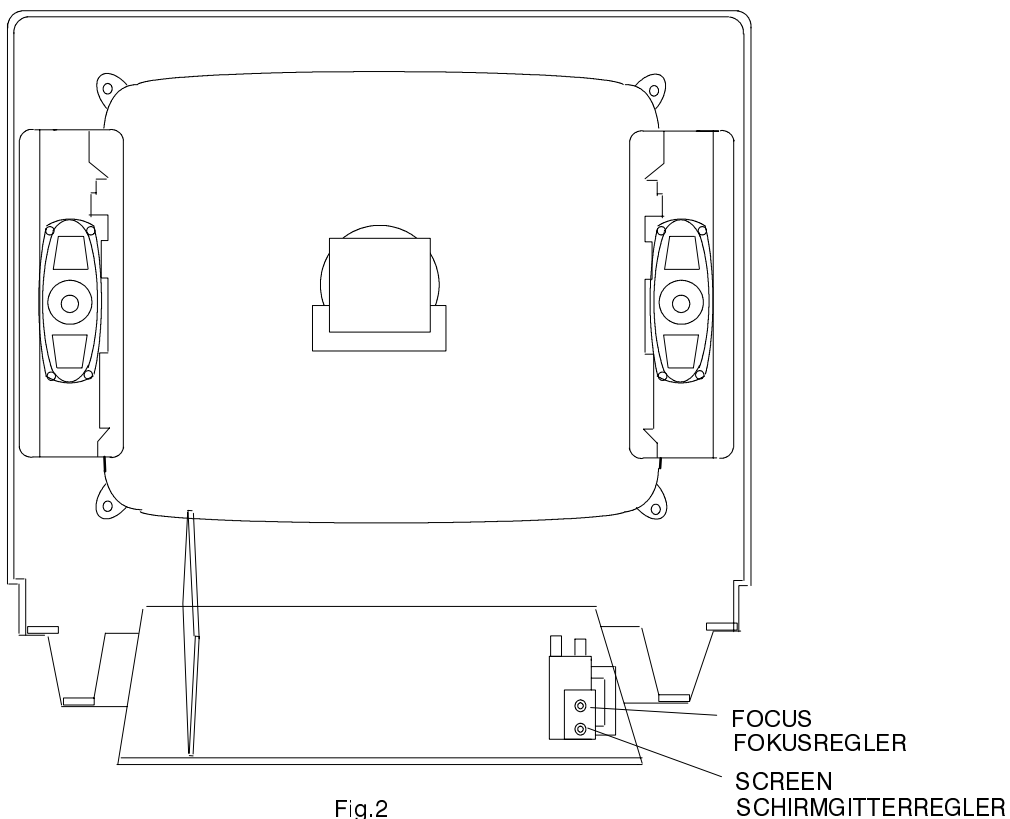

## SERVICE HINTS

### How to remove the rear cover

1. Remove the 5 screws (A) as shown in Fig.3/Fig.4.

## SERVICE HINWEISE

### Entfernen Der Geräterückwand

1. Die 5 Schrauben (A) entfernen, siehe Abb.3/Abb.4.

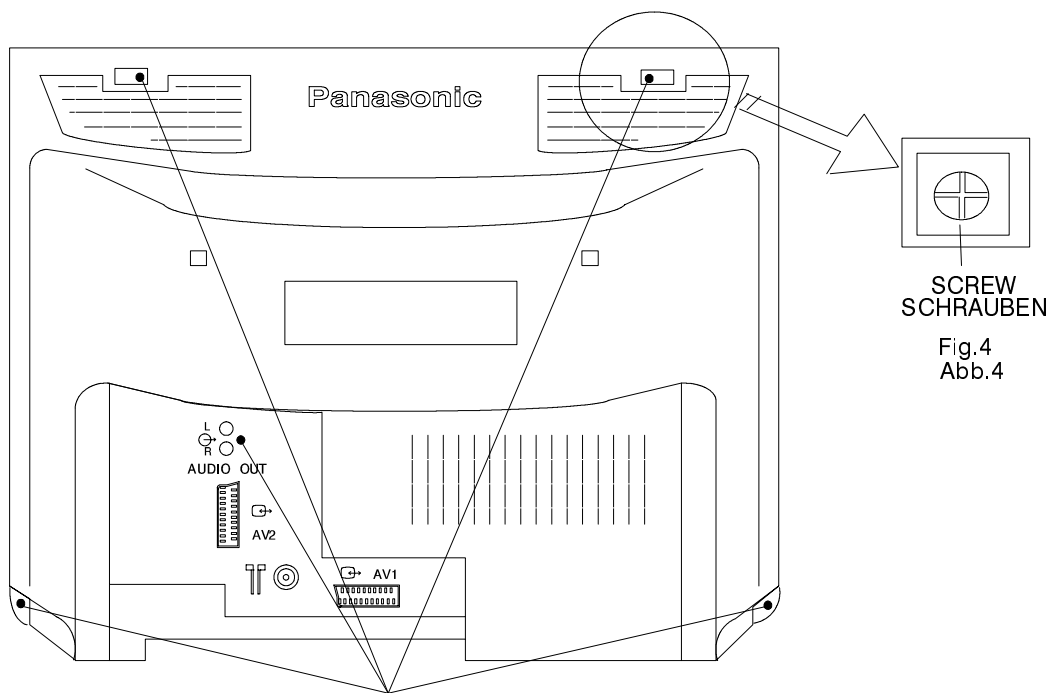

SCREWS (A)  
SCHRAUBEN A

Fig.3.  
Abb.3.

## ADJUSTMENT PROCEDURE

The remote control is used for entering and storing adjustments, with the exception of cut-off adjustments which must always be done prior to service adjustment. Perform adjustments in accordance with screen display. The display on the screen also specifies the CCU variants as well as the approx. setting values. The adjustment sequence for the service mode is indicated below.

1. Set the Bass to maximum position, set the Treble to minimum position, press the F button followed by the volume down button on the customer controls at the front of the TV and at the same time press the Reveal button on the remote control, this will place the TV into the Service Mode.
2. Press the RED / GREEN buttons to step up / down through the functions.
3. Press the YELLOW / BLUE buttons to alter the function values.
4. Press the STORE button after each adjustment has been made to store the required values.
5. To exit the Service Mode press the Normalisation button.

**NOTE:** This TV also has the option of using a Memory Pack which enables you to copy the preset TV channels into the Memory Pack and then download them onto this or any other EURO-2 TV set.

### TV to Memory Pack process

1. Plug the memory pack into the lower of the two 21 pin terminals at the back of the TV and switch the TV on. If the TV has only one 21 pin connector then this will be able to accept the memory pack.
2. Go into the Service Mode as explained above. The screen will show:—

Program  
External>>TV

3. Press the blue button on the remote control. The screen will show:—

Program  
TV>>External

4. Press the STORE button on the TV. The screen will show:—

Storing

5. All the tuning information stored inside the TV will now be transferred to the Memory Pack. This process will take 2–3 minutes to complete and when finished the screen will show:—

OK!

### Memory Pack to TV Process

1. Plug the memory pack into the lower of the two 21 pin terminals at the back of the TV and switch the TV on. If the TV has only one 21 pin connector then this will be able to accept the memory pack.
2. Go into the Service Mode as explained above. The screen will show:—

Program  
External>>TV

3. Press the STORE button on the TV. The screen will show:—

Loading

4. All the tuning information stored inside the Memory Pack will now be transferred to the TV. This process will take 2–3 minutes to complete and when finished the screen will show:—

OK!

5. The tuning information from the Memory Pack has now been copied into the TV.
6. To exit from the Service Mode press the Normalisation button.
7. The process has now been completed and the Memory Pack can now be removed.

## Errors

If an error occurs while using the Memory Pack the TV will detect this and the screen will show:—

Program  
Error!

If this happens then press the Normalisation button and repeat the process that was being used. If the errors continue to occur then check the connectors between the TV and the memory pack and check the 9V battery inside the memory pack.

## ABGLEICHVERFAHREN

Die Fernbedienung dient zum Eingeben und Abspeichern der Einstellwerte, mit Ausnahme der Sperrpunkteinstellung, die grundsätzlich vor den hier beschriebenen Einstellungen vorgenommen werden muss. Die Einstellung erfolgt entsprechend dem Bildschirm–Display. Auf dem Bildschirm–Display erscheinen auch die CCU–Varianten sowie die ungefähren Einstellwerte. Die Einstellfolge für den Service–Modus ist nachstehend beschrieben.

1. Den Tiefenregler auf Höchststellung und den Höhenregler auf Mindeststellung stellen. Nachdem die F–Taste am Bedienfeld des FS–Gerätes gedrückt wurde, die Die Taste "Lautstärke Minus" am FS–Gerät drücken und gleichzeitig die Taste "Reveal" auf der Fernbedienung betätigen. Hierdurch wird das FS–Gerät auf Service–Modus geschaltet.
2. Die einzelnen Funktionen mit Hilfe der ROTEN und GRÜNEN Taste anwählen.
3. Mit der GELBEN und BLAUEN Taste die Werte der einzelnen Funktionen ändern.
4. Nach jeder Einstellung die Taste STR auf der Fernbedienung oder am Bedienfeld drücken, um die geänderten Werte abzuspeichern.
5. Zum Verlassen des Service–Modus die "N"–Taste auf der Fernbedienung drücken

**HINWEIS:** Dieses FS–Gerät bietet auch die Möglichkeit eines Memory Pack, mit dem Sie die gewählten Fernsehkanäle abspeichern und auf jedes beliebige EURO2 FS–Gerät umkopieren können.

### Kopieren der Einstelldaten vom FS–Gerät in das Memory Pack

1. Das Memory Pack in die untere der beiden 21–poligen Steckerleisten an der Rückseite des FS–Geräts stecken und das Gerät einschalten. Wenn das FS–Gerät nur eine 21–polige Anschlussleiste hat, kann das Memory Pack auch an diese angeschlossen werden.
2. Wie schon oben beschrieben auf Service–Modus umschalten. Auf dem Bildschirm erscheint:

Program  
External >> TV

3. Nun die blaue Taste an der Fernbedienung betätigen. Auf dem Bildschirm erscheint:

Program  
TV >> External

4. Die Taste STORE am Fernseher drücken. Der Bildschirm meldet nun:

Storing

5. Die im FS–Gerät abgespeicherten Kanal–Einstelldaten werden nun in das Memory Pack überspielt. bei abgeschlossener Datenübertragung meldet der Bildschirm:

OK!

### Kopieren der Einstelldaten vom Memory Pack in das FS–Gerät

1. Das Memory Pack in die untere der beiden 21–poligen Steckerleisten an der Rückseite des FS–Geräts stecken und das Gerät einschalten. Wenn das FS–Gerät nur eine 21–polige Anschlussleiste hat, kann das Memory Pack auch an diese angeschlossen werden.
2. Wie schon oben beschrieben auf Service–Modus umschalten. Auf dem Bildschirm erscheint:

Program  
External >> TV

3. Die Taste STORE am Fernseher drücken. Der Bildschirm meldet nun:

Loading

4. Die im Memory Pack abgespeicherten Einstelldaten werden nun in das FS–Gerät überspielt. bei abgeschlossener Datenübertragung meldet der Bildschirm:

OK!

5. Die Kanal–Einstelldaten sind damit vom Memory Pack in das FS–Gerät überspielt.
6. Zum Verlassen des Service–Modus die "N"–Taste auf der Fernbedienung drücken
7. Der Kopiervorgang ist somit abgeschlossen, und das Memory Pack kann von der Steckerleiste abgezogen werden.

## Fehler

Falls beim Gebrauch des Memory Packs Fehler auftreten, zeigt das FS–Gerät dies auf dem Bildschirm mit der folgenden Meldung an:

Program  
Error!

In diesem Fall muss der Service–Modus durch Drücken der "N"–Taste auf der Fernbedienung verlassen und anschliessend der Vorgang wiederholt werden. Falls weiterhin Fehlermeldungen erscheinen, müssen die Anschlusskontakte zwischen FS–Gerät und Memory Pack sowie die 9V Batterie im Memory Pack kontrolliert werden.



## ADJUSTMENT PROCEDURE

Item/Preparation	Adjustments
<b>+B SET – UP</b> 1. Receive a test pattern 2. Set the controls: Brightness      minimum Contrast         minimum Volume           minimum	1. Set the +B voltage up as follows: Adjust <b>R811</b> so that <b>B2</b> shows $130V \pm 1V$ 2. Confirm the following voltages. <b>B1</b> $200 \pm 10V$ <b>B6</b> $12 \pm 0.5V$ <b>B3</b> $27 \pm 1V$ <b>B7</b> $5 \pm 0.1/-0.25V$ <b>B4</b> $35.5 \pm 1V$ <b>B8</b> $5 \pm 0.25V$ <b>B5</b> $15.5 \pm 1V$ <b>U33</b> $31 \pm 1V$
<b>RF AGC</b> 1. Receive a test pattern. 2. Connect an oscilloscope between the tuner RF AGC and ground. 3. Set the oscilloscope gain range to 1V/div.	1. Check that the noise becomes large when the RF AGC VR <b>R126</b> is turned counterclockwise. After the check adjust to previous setting (clockwise). 2. Gradually turn the RF AGC VR anti-clockwise, and set the RF AGC VR to the point where the RF AGC voltage is just falling to a point where this voltage drops by 0.2V from the maximum value.
<b>CUT OFF</b> 1. Receive a test pattern. 2. Degauss the tube externally. 3. Set the TV into Service Mode 1. 4. Select Cutoff DC mode.	1. Confirm the value is 128 and select Ug2 mode noting colour with largest value 2. Turn the screen VR until a colour reaches 20~30. 3. Connect an oscilloscope to the cathode with the biggest value colour. 4. Select Cutoff DC mode and adjust Cutoff pulse to $159V \pm 5V$ . 5. Disconnect the oscilloscope and adjust the screen to whichever colour reaches $70 \pm 30$ first.

## ABGLEICH

Vorbereitung	Abgleich
<b>+B – Abgleich</b> 1. Testbild empfangen. 2. Helligkeit auf Minimum Kontrast auf Minimum Lautstärke auf Minimum	1. Mit <b>R811</b> muß die <b>B2</b> auf $130V \pm 1V$ eingestellt werden. 2. Folgende Spannungen sind zu überprüfen : <b>B1</b> $200 \pm 10V$ <b>B6</b> $12 \pm 0.5V$ <b>B3</b> $27 \pm 1V$ <b>B7</b> $5 \pm 0.1/-0.25V$ <b>B4</b> $35.5 \pm 1V$ <b>B8</b> $5 \pm 0.25V$ <b>B5</b> $15.5 \pm 1V$ <b>U33</b> $31 \pm 1V$
<b>RF AGC</b> 1. Testbild empfangen. 2. An die Tuner RF AGC und Masse ein Oszilloskop anschließen. 3. Die Empfindlichkeit des Oszilloskopes auf 1V/div. einstellen.	1. Wenn das Poti <b>R126</b> (RF AGC) gegen den Uhrzeigersinn gedreht wird. muß das Rauschen zunehmen. 2. Das Poti R126 gegen den Uhrzeigersinn so einstellen, daß die eingestellte Spannung um 0,2V unter dem Maximalwert
<b>CUT OFF</b> 1. Testbild empfangen. 2. Bildröhre entmagnetisieren. 3. Service–Mode 1 anwählen. 4. Im Service–Mode den Abgleichpunkt Cutoff DC–Mode wählen (14).	1. Im Feld Cutoff DC muß der Wert 128 stehen, Im Ugz–Feld muß Farbe mit dem höchstem Wert notiert werden. 2. Mit dem Screen–Poti wird die Farbe auf 20 bis 30 eingestellt. 3. An die Kathode mit den höchsten Wert (aus Punkt 1) wird ein Oszilloskop angeschlossen. 4. Im Cutoff DC Mode wird der Cutoff–Puls auf $159V \pm 5V$ eingestellt. 5. Das Oszilloskop entfernen und im Cutoff Mode die Werte so einstellen, daß sie alle bis $70 \pm 30$ liegen.

**ALIGNMENT SETTINGS** (The figures used below are nominal and used for representative purposes only)

Alignment Function	TX-21AD3F	Settings / Special features
1. Vertical amplitude	V-AMP 051	Optimum setting
2. Vertical symmetry	V-SYM 013	
3. Vertical linearity	V-LIN 012	
4. Vert. DC.	Vert. D.C.. 000	Not to be adjusted.
5. V-Pos.	V. Pos. 003	Optimum setting
6. Horizontal amplitude	H-AMP -033	Optimum setting
7. Horizontal position	H-POS 049	
8. Text Position	TEXT POSITION 045	Optimum setting
9. EW-amplitude	E-W-AMP 1 -058	Optimum setting
10. EW-amplitude	E-W-AMP 2 023	Optimum setting
11. Trapezium-comp	TRAPEZ-1 -014	Optimum setting
12. Trapezium- comp	TRAPEZ-2 012	Optimum setting
13. Colour VCO	Colour VCO 015	Press either Blue or Yellow buttons to effect automatic adjustment
14. Cut-off DC	Cut-off DC 050	Not to be adjusted.
15. Ug2 Test	Ug 2 Test 107   021   023	Select Cutoff DC in Service Mode mode and confirm the value is 128. Select Ug 2 Test noting colour with largest value, adjust on FBT until a colour reaches 20 ~ 30. Connect an oscilloscope to the cathode of the biggest value colour, select Cutoff DC mode and adjust get Cutoff pulse voltage to 159 ± 5V. Disconnect the oscilloscope and adjust the screen to whichever colour reaches 70 ± 30 first.
16. Cutoff	Cutoff 045   055   050	Press the GREEN button to step through the settings. Adjust for optimum.
17. White	White 224   255   237	Press the GREEN button to step through the settings. Adjust for optimum.

## ABGLEICHTABELLE

(Die angegebenen Werte sind Mittelwerte und Können individuell nach oben oder unten nach dem korrekten Abgleich abweichen)

Abgleichfunktion	TX-21AD3F	Einstellung/Besondere Merkmale
1. Vertikale Amplitude	V-AMP 051	Optimale Einstellung
2. Vertikale symmetrie	V-SYM 013	
3. Vertical linearität	V-LIN 012	
4. Vert. DC.	Vert. D.C.. 000	Nicht einstellen
5. V-Pos.	V. Pos. 003	Optimale Einstellung
6. Horizontale Amplitude	H-AMP -033	Optimale Einstellung
7. Horizontale position	H-POS 049	
8. Text Position	TEXT POSITION 045	Optimale Einstellung
9. OW-amplitude	E-W-AMP 1 -058	Optimale Einstellung
10. OW-amplitude	E-W-AMP 2 023	Optimale Einstellung
11. Trapez-Kompensation	TRAPEZ-1 -014	Optimale Einstellung
12. Trapez-Kompensation	TRAPEZ-2 012	Optimale Einstellung
13. Colour VCO	Colour VCO 015	Auf minimale Schwebung einstellen.
14. Cut-off DC	Cut-off DC 050	Nicht einstellen
15. Bildschirm	Ug 2 Test 107   021   023	Wählen Sie den Cutoff DC Im Service Mode und bestätigen Sie den Wert 128. Im Ug2-Feld muß die Farbe mit dem höchsten Wert notiert werden. Mit dem Screen-Poti wird die Farbe auf 20 bis 30 eingestellt. An die Kathode mit den höchsten Wert (aus Punkt 1) wird ein Oszilloskop angeschlossen. Im Cutoff DC Mode wird der Cutoff-Puls auf $159V \pm 5V$ eingestellt. Das Oszilloskop entfernen und im Cutoff Mode die Werte so einstellen, daß sie alle bis $70 \pm 30$ liegen.
16. Cutoff	Cutoff 045   055   050	Die Einstellungen mit Hilfe der GRÜNEN Taste anwählen. Optimale Einstellung.
17. White	White 224   255   237	Die Einstellungen mit Hilfe der GRÜNEN Taste anwählen. Optimale Einstellung.

## SELF CHECK

Self check is used to automatically check the Bus Lines and Hexadecimal code of the TV set.

To get into the Self Check mode press the F button followed by the volume down button on the customer controls at the front of the TV at the same time pressing the Status button, on the Remote Control, and the screen will show: –

1	—	ok	Tuner	11	—	--	Dolby IC for C/R
2	—	ok	VIF	12	—	ok	P S MODE
3	—	ok	EEPROM	13	—	ok	P TA0
4	—	--	Sound AV switch1	14	—	ok	P TA1
5	—	ok	Video AV switch1	15	—	ok	P TA2
6	—	ok	VDP	16	—	ok	P TA3
7	—	ok	TPU	17	—	ok	P SDA
8	—	ok	MSP	18	—	ok	P SCL1
9	—	--	Dolby Sub	19	—	ok	P SCL3
10	—	--	Dolby IC for L/R	20	—	ok	P SCL4

If the CCU ports have been checked and found to be incorrect then "--" will appear in place of "OK".

### Hex codes

21	—	ok	P SBLED	6A
22	—	ok	P OFF	22
23	—	ok	P DEFL	21
24	—	ok	P RAM	94
				95

## SELBSTDIAGNOSE

1) Die Selbstdiagnose dient zum automatischen Prüfen der Bus-Leitungen sowie des Hexadezimalcodes des FS-Geräts.

Zum Umschalten auf Selbstdiagnose nach dem Drücken der "F"-Taste die "Lautstärke Minus" Taste am Bedienfeld des FS-Geräts und gleichzeitig die Taste "Status" an der Fernbedienung drücken; auf dem Bildschirm erscheint hierauf: –

2) Nach der Selbstdiagnose wird das Gerät automatisch auf sämtliche werksseitigen Standardeinstellungen zurückgesetzt.

1	—	ok	Tuner	11	—	--	Dolby IC for C/R
2	—	ok	ZF-Verstärker	12	—	ok	P S MODE
3	—	ok	EEPROM	13	—	ok	P TA0
4	—	--	Audio AV-Schalter 1	14	—	ok	P TA1
5	—	ok	Video AV switch1	15	—	ok	P TA2
6	—	ok	Video AV-Schalter 1	16	—	ok	P TA3
7	—	ok	Video AV-Schalter 2	17	—	ok	P SDA
8	—	ok	MSP	18	—	ok	P SCL1
9	—	--	Dolby Sub	19	—	ok	P SCL3
10	—	--	Dolby IC for L/R	20	—	ok	P SCL4

Wenn der Hauptprozessor (CCU) an den Anschlüssen einen Fehler finden sollte, oder der Anschluss nicht belegt ist, zeigt die entsprechende Position -- anstelle von OK an.

### Hexadezimalcode

21	—	ok	P SBLED	6A
22	—	ok	P OFF	22
23	—	ok	P DEFL	21
24	—	ok	P RAM	94
				95

# WAVEFORM PATTERN TABLE

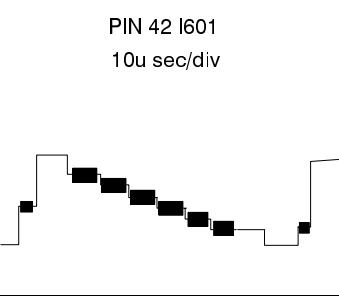
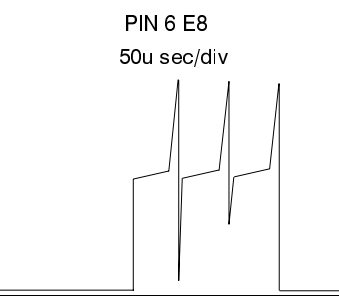
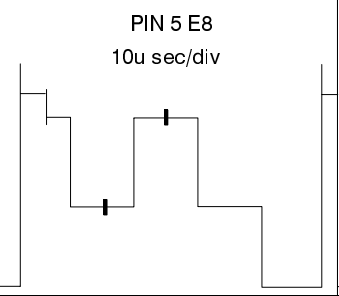
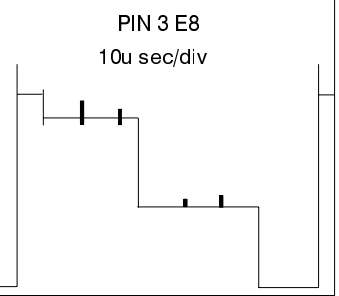
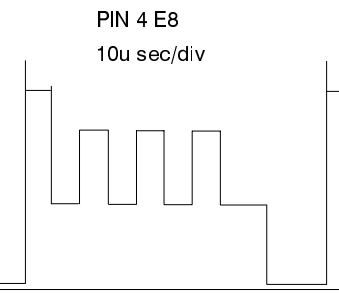
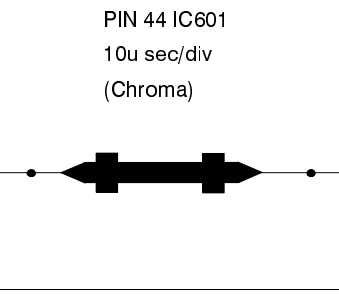
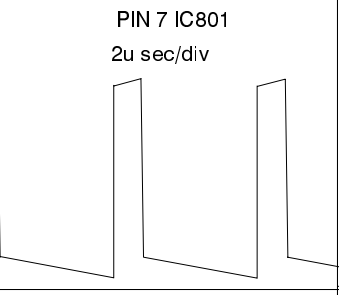
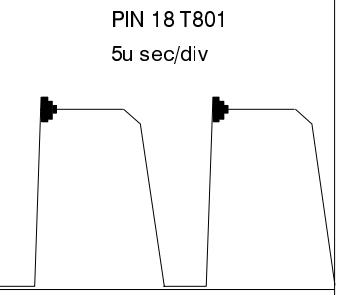
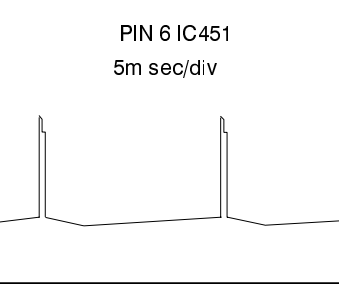
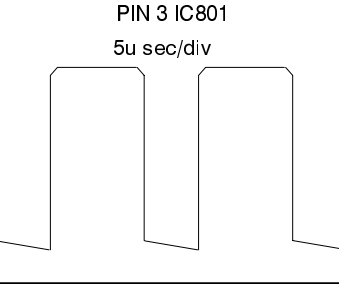
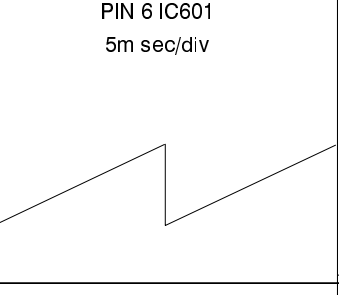
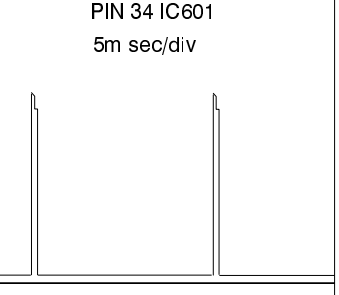
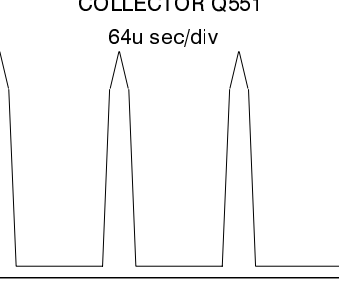
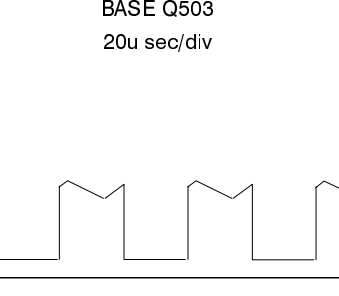
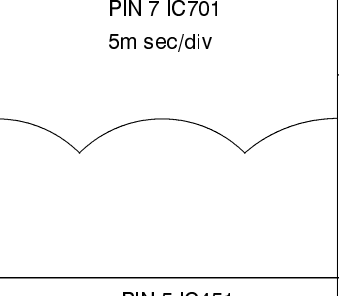
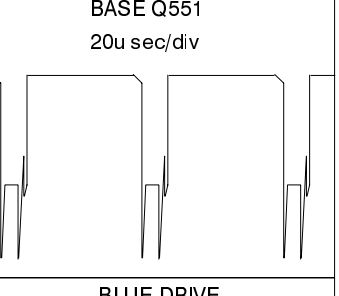
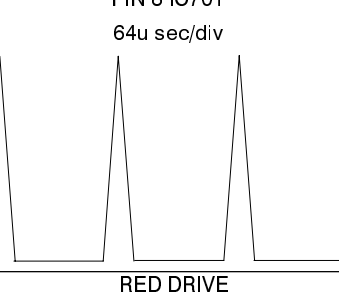
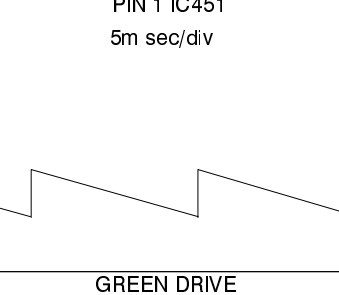
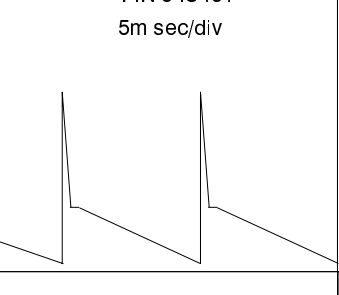
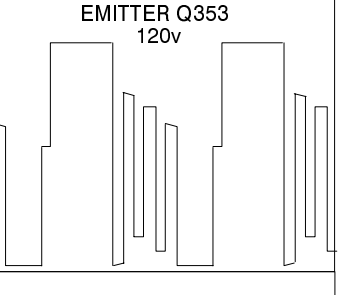
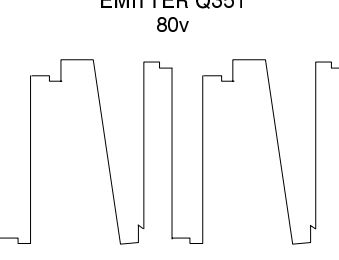
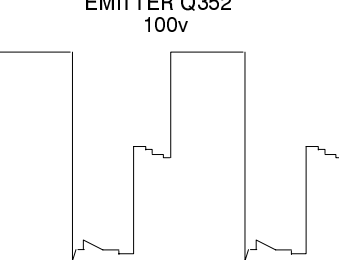
<p>PIN 42 I601 10u sec/div</p> 	<p>PIN 6 E8 50u sec/div</p> 	<p>PIN 5 E8 10u sec/div</p> 	<p>PIN 3 E8 10u sec/div</p> 
<p>PIN 4 E8 10u sec/div</p> 	<p>PIN 44 IC601 10u sec/div (Chroma)</p> 	<p>PIN 7 IC801 2u sec/div</p> 	<p>PIN 18 T801 5u sec/div</p> 
<p>PIN 6 IC451 5m sec/div</p> 	<p>PIN 3 IC801 5u sec/div</p> 	<p>PIN 6 IC601 5m sec/div</p> 	<p>PIN 34 IC601 5m sec/div</p> 
<p>COLLECTOR Q551 64u sec/div</p> 	<p>BASE Q503 20u sec/div</p> 	<p>PIN 7 IC701 5m sec/div</p> 	<p>BASE Q551 20u sec/div</p> 
<p>PIN 8 IC701 64u sec/div</p> 	<p>PIN 1 IC451 5m sec/div</p> 	<p>PIN 5 IC451 5m sec/div</p> 	<p>BLUE DRIVE EMITTER Q353 120v</p> 
<p>RED DRIVE EMITTER Q351 80v</p> 	<p>GREEN DRIVE EMITTER Q352 100v</p> 		

# AUDIO BLOCK DIAGRAM TONSIGNAL BLOCKSCHEMA

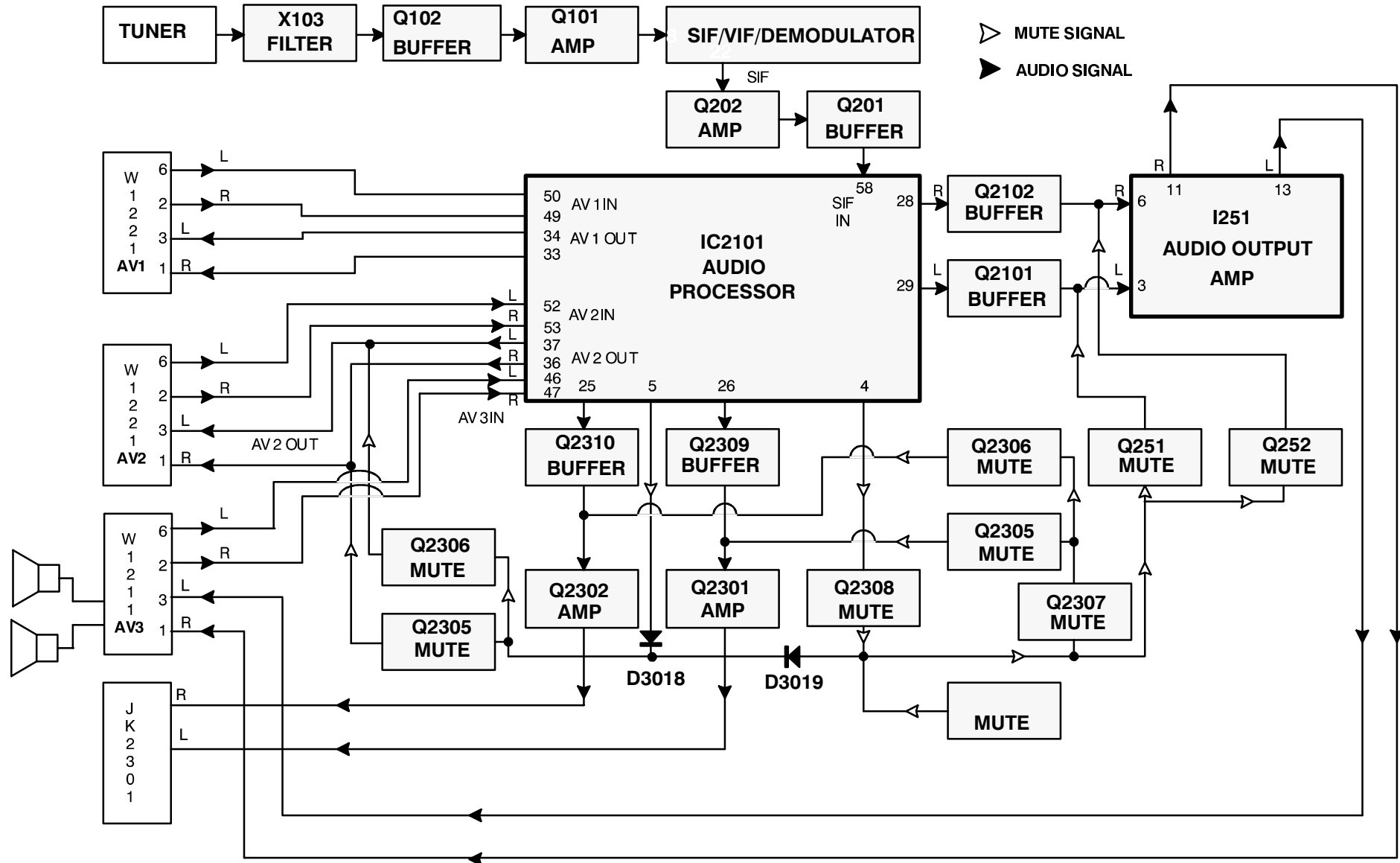

# POWER SUPPLY AND CONTROL BLOCK DIAGRAM STROMVERSORGUNGS BLOCKSCHEMA

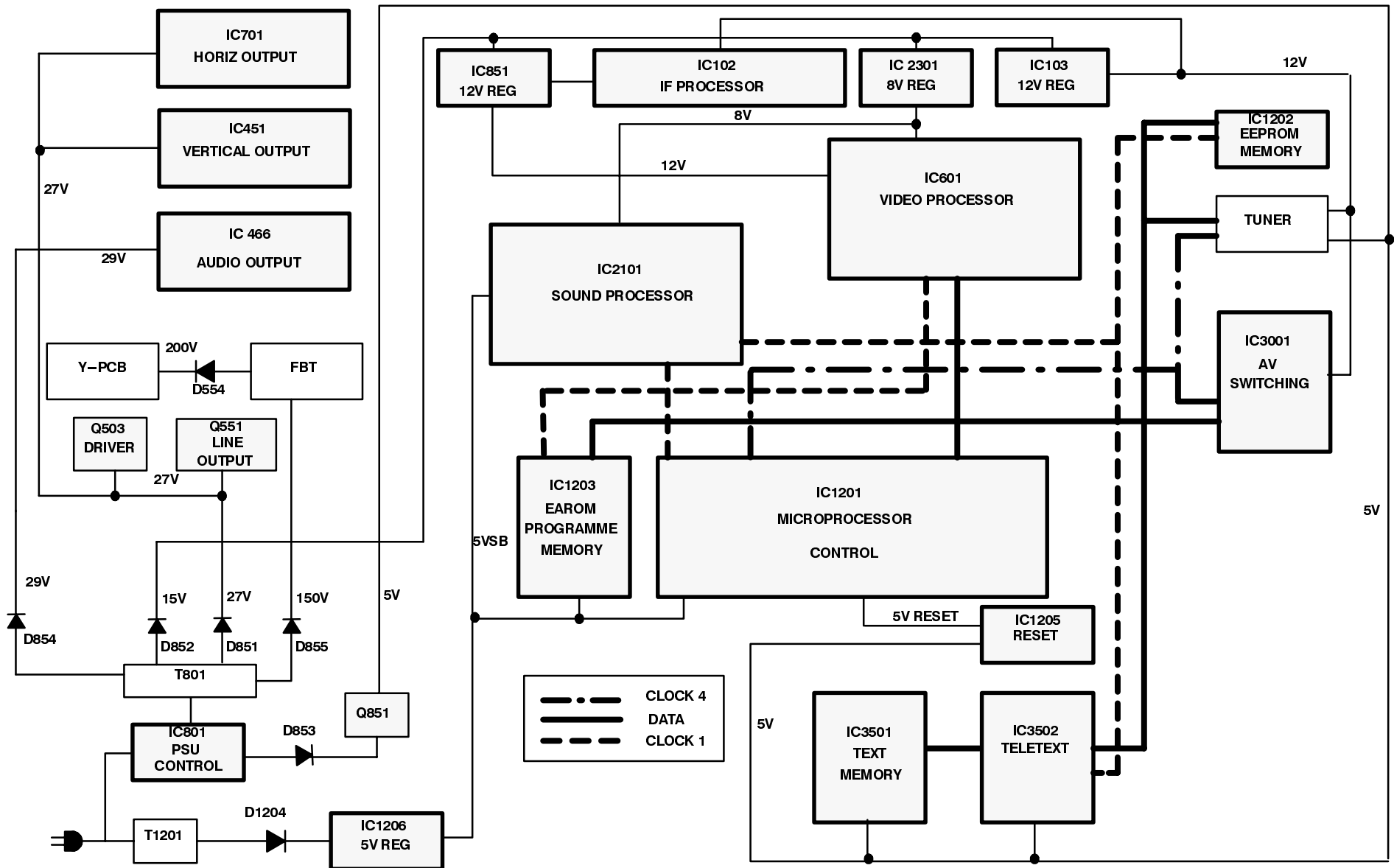

# VIDEO BLOCK DIAGRAM BILD SIGNAL BLOCKSCHEMA

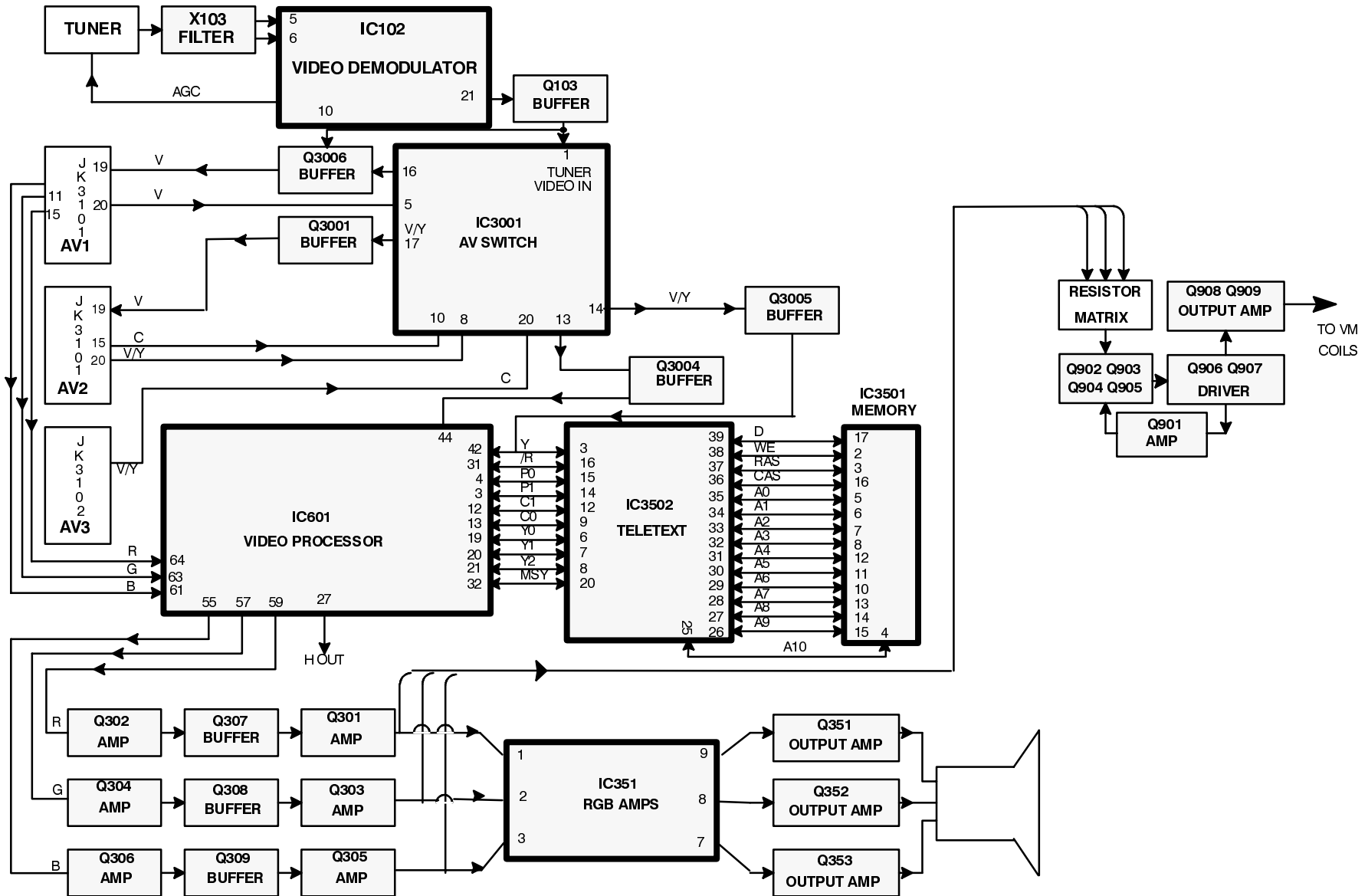



**NOTE :**

The numbers on the exploded view below refer to the miscellaneous section of the Replacement Parts List.

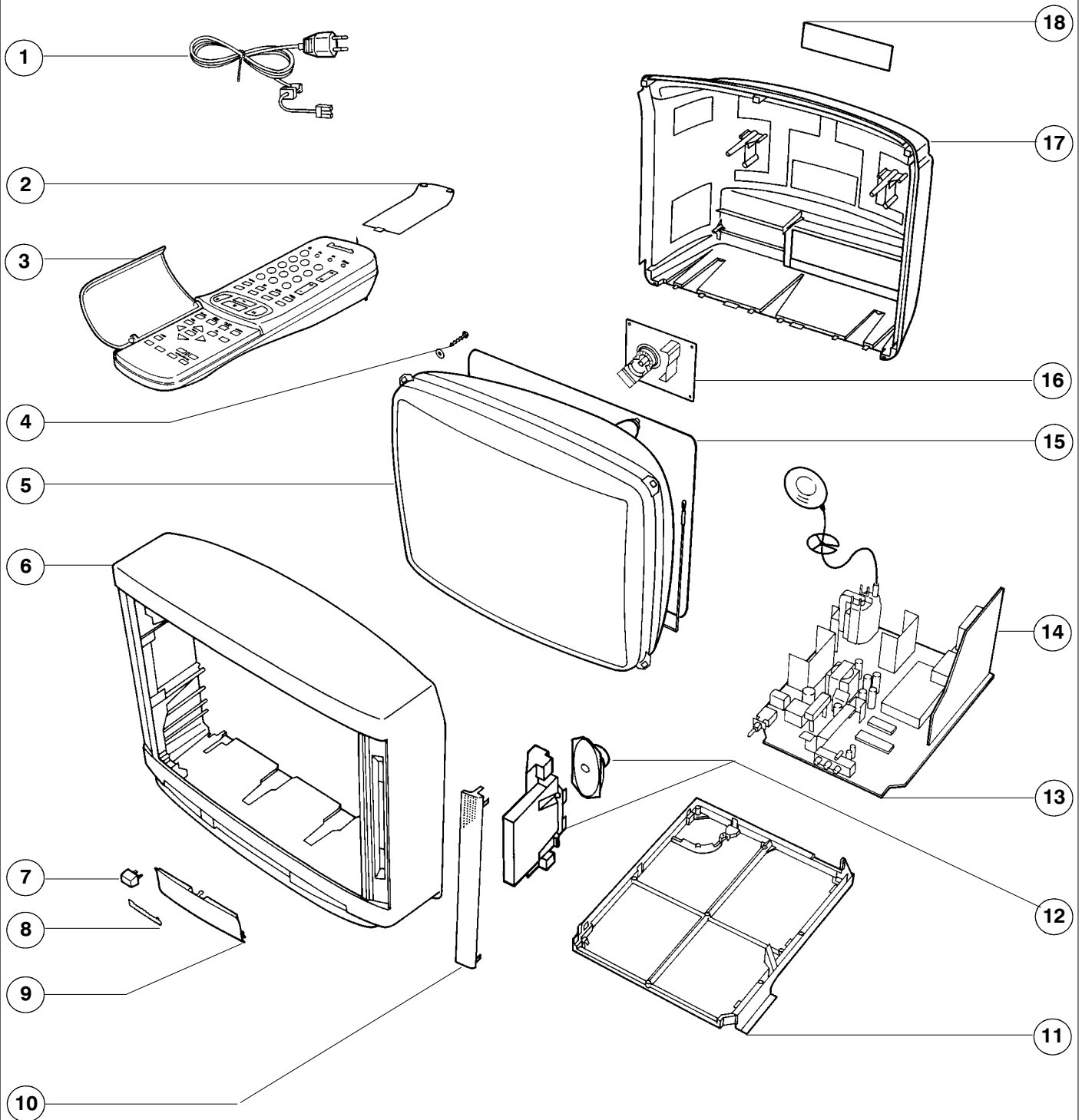

## REPLACEMENT PARTS LIST

### Important Safety Notice

Components identified by  $\Delta$  mark have special characteristics important for safety.  
When replacing any of these components, use only manufacturer's specified parts.

Ref No.	Part No.	Description	
<b>MISCELLANEOUS COMPONENTS</b>			
1)	TSX8E0020	POWER CORD	$\Delta$
2)	UR51EC780	BATTERY COVER (REMOTE)	
3)	EUR51920	REMOTE CONTROL	
4)	VP15005-35	SCREW	
5)	A51ECQ51X01	CRT	$\Delta$
6)	TKY8E092	CABINET	$\Delta$
7)	TBX8E030	POWER BUTTON	
8)	TBM8E1726	PANASONIC BADGE	
9)	TKP8E1138AD2	DOOR LID	
10)	TKP8E1139	SPEAKER NET	
11)	TMX8E010	CHASSIS BRACKET	
12)	EAGG1218D2	SPEAKER	
13)	TNP8EE008BJ	E P.C.B.	$\Delta$
14)	TNP8EB007AB	B PCB	$\Delta$
15)	TLK8E05117	DEGAUSS COIL	
16)	TNP117069AD	Y P.C.B.	$\Delta$
17)	TKU8E00240	BACK COVER	$\Delta$
18)	TBM8E1717	MODEL LABEL	
	TNP8EP013AB	P .P.C.B.	$\Delta$
	TBM8E1605	PRESET LABEL	
	31221212478	FIX CLIP	
	TES4537	SPRING	
	TEK6935	LID SWITCH	
	TKP8E1140	LED TUBE	
TNR1	ENG29501G	TUNER	
	TMW8E022	LED HOLDER	
S.351	0330550049	CRT SOCKET	
	TBM8E1535	A.V.LABEL	
	F9-4-220	RELAY	
	TPC8E4639	OUTER CARTON	
	TPD8E615	CUSHION-TOP	
	TPD8E616	CUSHION-BOTTOM	
	TQB8E2344A	GERMAN INST BOOK	$\Delta$
	TQB8E2344B	DUTCH INST BOOK	$\Delta$
	TQB8E2344C	ITALIAN INST BOOK	$\Delta$
	TQB8E2344D	FRENCH INST BOOK	$\Delta$
	TQB8E2344E	SPANISH INST BOOK	$\Delta$
	TQB8E2344J	PORTUGUESE INST BOOK	$\Delta$
	ERC12GK825	SOLID 0.5W 10% 8M2 $\Omega$	
	UM-3DJ-2P	BATTERY-SET	
<b>CAPACITORS</b>			
C100	ECUV1H104ZFX	S.M.CAP 50V 100nF	
C101	ECUV1H104ZFX	S.M.CAP 50V 100nF	
C102	ECUV1H104ZFX	S.M.CAP 50V 100nF	
C103	ECUV1H104ZFX	S.M.CAP 50V 100nF	
C104	ECUV1H104ZFX	S.M.CAP 50V 100nF	
C107	ECUV1H104ZFX	S.M.CAP 50V 100nF	
C124	ECEA1CKA470	ELECT 16V 47 $\mu$ F	
C130	ECEA1CKA470	ELECT 16V 47 $\mu$ F	
C135	ECUV1H103ZFX	S.M.CAP 50V 10nF	
C136	ECA1CM100GB	ELECT 16V 10pF	
C137	ECA1EM101GB	ELECT 25V 1 $\mu$ F	
C138	ECUV1H103ZFX	S.M.CAP 50V 10nF	
C139	ECUV1H390JCX	S.M.CAP 50V 39pF	
C140	ECUV1H390JCX	S.M.CAP 50V 39pF	
C141	ECUV1H103ZFX	S.M.CAP 50V 10nF	
C144	ECA1HMR33GB	ELECT 50V 0.33 $\mu$ F	

Ref No.	Part No.	Description	
C145	ECUV1H103ZFX	S.M.CAP 50V 10nF	
C146	ECUV1H104ZFX	S.M.CAP 50V 100nF	
C147	ECUV1H102KBX	S.M.CAP 50V 1nF	
C148	ECEA1HKAR22	ELECT 50V 0.22 $\mu$ F	
C149	ECA1EM470GB	ELECT 25V 47pF	
C150	ECUV1H103ZFX	S.M.CAP 50V 10nF	
C151	ECUV1H104ZFX	S.M.CAP 50V 100nF	
C154	ECA1CM221GB	ELECT 16V 220pF	
C170	ECUV1H331KBX	S.M.CAP 50V 330pF	
C201	ECUV1H070DCX	S.M.CAP 50V 7pF	
C202	ECUV1H070DCX	S.M.CAP 50V 7pF	
C203	ECUV1H470JX	S.M.CAP 50V 47pF	
C204	ECUV1H560JCX	S.M.CAP 50V 56pF	
C205	ECUV1H560JCX	S.M.CAP 50V 56pF	
C207	ECUV1H560JCX	S.M.CAP 50V 56pF	
C209	ECUV1H104ZFX	S.M.CAP 50V 100nF	
C210	ECUV1H103ZFX	S.M.CAP 50V 10nF	
C211	ECUV1H104ZFX	S.M.CAP 50V 100nF	
C251	ECA1EM100GB	ELECT 25V 0.1 $\mu$ F	
C252	ECUY1H563KBX	S.M.CAP 50V 56nF	
C253	ECA1HM4R7GB	ELECT 50V 4.7 $\mu$ F	
C254	ECQM1H104J	FILM 50V 100nF	
C255	ECEA1EGE101	ELECT 25V 100 $\mu$ F	
C256	ECUY1H563KBX	S.M.CAP 50V 56nF	
C257	ECA1HM4R7GB	ELECT 50V 4.7 $\mu$ F	
C258	ECA1EM100GB	ELECT 25V 0.1 $\mu$ F	
C259	ECQM1H104J	FILM 50V 100nF	
C260	ECA1VM102GE	ELECT 35V 1nF	
C261	ECA1VM102GE	ELECT 35V 1nF	
C262	ECQM1H474J	FILM 50V 470nF	
C263	ECA1HM010GB	ELECT 50V 1pF	
C264	ECEA1HGE222	ELECT 50V 2200 $\mu$ F	
C265	ECQM1H474J	FILM 50V 470nF	
C266	ECA1HM010GB	ELECT 50V 1pF	
C267	ECUV1H104KBX	S.M.CAP 50V 100nF	
C268	ECUV1H104KBX	S.M.CAP 50V 100nF	
C271	ECUV1H561KBX	S.M.CAP 50V 560pF	
C301	ECA1CM470GB	ELECT 16V 47 $\mu$ F	
C302	ECUV1H104ZFX	S.M.CAP 50V 100nF	
C303	ECUV1H104ZFX	S.M.CAP 50V 100nF	
C310	ECUV1H104ZFX	S.M.CAP 50V 100nF	
C354	ECQM2104KZ	FILM 250V 100nF	
C355	ECUV1H222JCX	S.M.CAP 50V 2.2nF	
C356	ECUV1H222JCX	S.M.CAP 50V 2.2nF	
C357	ECUV1H222JCX	S.M.CAP 50V 2.2nF	
C358	222236516224	FILM 160V 220nF	
C360	ECKC3D152J	CERAMIC 2KV 1.5nF	$\Delta$
C361	ECA1HMR47GB	ELECT 50V 0.47 $\mu$ F	
C451	ECUV1H102JX	S.M.CAP 50V 1nF	
C452	ECUV1H102ZFX	S.M.CAP 50V 1nF	
C453	ECUV1H472KBX	S.M.CAP 50V 4.7nF	
C454	ECUV1H104ZFX	S.M.CAP 50V 100nF	
C455	ECA1VM222GE	ELECT 35V 2.2nF	
C456	ECEA1HGE221	ELECT 50V 220 $\mu$ F	
C457	ECUV1H103KBX	S.M.CAP 50V 10nF	
C458	ECQM1H273J	FILM 50V 27nF	
C459	222236516154	FILM 160V 150nF	
C460	222236516105	FILM 160V 1 $\mu$ F	
C462	ECEA1VGE332	ELECT 35V 3300 $\mu$ F	
C463	ECQB1H222J	FILM 50V 2200pF	
C501	ECA1AM330GB	ELECT 10V 33pF	
C506	ECUV1H103ZFX	S.M.CAP 50V 10nF	
C508	222236516105	FILM 160V 1 $\mu$ F	

Ref No.	Part No.	Description			
C509	ECEA1HGE101	ELECT	50V	100µF	
C510	ECUV1H104ZFX	S.M.CAP	50V	100nF	
C511	ECQM2683JZ	FILM	250V	68nF	
C551	ECWH12H272J	CERAMIC	1250V	2.7nF	△
C552	ECWH12H102J	FILM	1250V	1nF	△
C555	ECWH12H103J	FILM	1250V	10nF	△
C556	ECQF4273JZH	FILM	400V	0.027µF	
C559	ECWF2H474J	FILM	500V	470nF	△
C562	ECKC2H101J	CERAMIC	500V	100pF	△
C563	ECEA2EU220	ELECT	250V	22µF	
C564	ECEA2AU2R2	ELECT	100V	2.2µF	
C565	ECQP1H273J	FILM	100V	2700µF	
C601	ECUV1H271JCX	S.M.CAP	50V	270pF	
C602	ECUV1H121JCX	S.M.CAP	50V	120pF	
C603	ECUV1H471JCX	S.M.CAP	50V	470pF	
C604	ECA0JM102GB	ELECT	6.3V	1nF	
C605	ECUV1H103ZFX	S.M.CAP	50V	10nF	
C608	ECUV1H683ZFX	S.M.CAP	50V	68nF	
C609	ECA1CM470GB	ELECT	16V	47µF	
C610	ECUV1H683ZFX	S.M.CAP	50V	68nF	
C611	ECUV1H104ZFX	S.M.CAP	50V	100nF	
C612	ECUV1H103ZFX	S.M.CAP	50V	10nF	
C613	ECUV1H102JCX	S.M.CAP	50V	1nF	
C614	ECUV1H104ZFX	S.M.CAP	50V	100nF	
C615	ECUV1H103ZFX	S.M.CAP	50V	10nF	
C616	ECUV1H103ZFX	S.M.CAP	50V	10nF	
C618	ECUV1H473ZFX	S.M.CAP	50V	47nF	
C619	ECUV1H104ZFX	S.M.CAP	50V	100nF	
C620	ECUV1H104ZFX	S.M.CAP	50V	100nF	
C621	ECA1CM100GB	ELECT	16V	10pF	
C622	ECA1CM100GB	ELECT	16V	10pF	
C623	ECUV1H104ZFX	S.M.CAP	50V	100nF	
C624	ECUV1H103ZFX	S.M.CAP	50V	10nF	
C625	ECEA1HNR22	ELECT	50V	0.22µF	
C626	ECA0JM102GB	ELECT	6.3V	1nF	
C627	ECUV1H100DCX	S.M.CAP	50V	10pF	
C628	ECUV1H470JCX	S.M.CAP	50V	47pF	
C629	ECUV1H101JCX	S.M.CAP	50V	100pF	
C630	ECUV1H104ZFX	S.M.CAP	50V	100nF	
C631	ECUV1H104ZFX	S.M.CAP	50V	100nF	
C632	ECUV1H104ZFX	S.M.CAP	50V	100nF	
C633	ECUV1H102JCX	S.M.CAP	50V	1nF	
C636	ECUV1H101JCX	S.M.CAP	50V	100pF	
C637	ECUV1H102KBX	S.M.CAP	50V	1nF	
C638	ECUV1H181JCX	S.M.CAP	50V	180pF	
C639	ECUV1H561KBX	S.M.CAP	50V	560pF	
C701	ECEA1HU101	ELECT	50V	100µF	
C702	ECUV1H103KBX	S.M.CAP	50V	10nF	
C703	ECA1HM100GB	ELECT	50V	10pF	
C704	ECQB1H223K	FILM	50V	22nF	
C705	ECQB1H152K	FILM	50V	1.5nF	
C801	ECUV1H101JCX	S.M.CAP	50V	100pF	
C802	ECQE6104K	FILM	600V	100nF	△
C803	ECUV1H560JX	S.M.CAP	50V	56pF	
C804	ECA1HM101GB	ELECT	50V	100pF	
C805	ECUV1H104ZFX	S.M.CAP	50V	100nF	
C806	ECEA1HU101	ELECT	50V	100µF	
C807	ECEA1EGE101	ELECT	25V	100µF	
C808	ECQB1H103J	FILM	50V	10nF	
C809	ECQB1H103J	FILM	50V	10nF	
C811	ECEA1HN010	ELECT	50V	1µF	
C815	ECKC2H472J	CERAMIC	500V	4.7nF	△
C816	ECKC3D222JB	CERAMIC	2KV	2200pF	△
C817	ECQB1H223K	FILM	50V	22nF	
C818	ECKC2H472J	CERAMIC	500V	4.7nF	△
C820	ECOS2GA151CB	ELECT	400V	150pF	
C821	ECKWNA332MECC	CERAMIC	250V	3.3nF	
C841	222233510224	CAPACITOR		0.22µF	
C851	ECKC2H681J	CERAMIC	500V	680pF	△
C852	ECEA1HU102	ELECT	50V	1000µF	
C853	ECEA1EGE222	ELECT	25V	2200µF	
C854	ECEA1HGE102	ELECT	50V	1000µF	

Ref No.	Part No.	Description			
C855	ECKC3D471JB	CERAMIC	2KV	470pF	△
C856	ECEA1EGE222	ELECT	25V	2200µF	
C857	ECA2CM101E	ELECT	160V	100µF	
C858	ECUV1H103ZFX	S.M.CAP	50V	10nF	
C859	ECUV1H103ZFX	S.M.CAP	50V	10nF	
C860	ECA1CM471GB	ELECT	16V	470pF	
C861	ECA2CGE221	ELECT	160V	220µF	
C862	ECA1CM471GB	ELECT	16V	470pF	
C1051	ECA0JM101G	ELECT	6.3V	100pF	
C1052	ECUV1H104ZFX	S.M.CAP	50V	100nF	
C1201	ECUV1H332KBX	S.M.CAP	50V	3.3nF	
C1202	ECUV1H332KBX	S.M.CAP	50V	3.3nF	
C1203	ECUV1H332KBX	S.M.CAP	50V	3.3nF	
C1204	ECUV1H332KBX	S.M.CAP	50V	3.3nF	
C1205	ECUV1H103ZFX	S.M.CAP	50V	10nF	
C1206	ECA1HM4R7GB	ELECT	50V	4.7µF	
C1207	ECUV1H472KBX	S.M.CAP	50V	4.7nF	
C1208	ECUV1H390JCX	S.M.CAP	50V	39pF	
C1209	ECUV1H390JCX	S.M.CAP	50V	39pF	
C1210	ECUV1H103ZFX	S.M.CAP	50V	10nF	
C1211	ECUV1H470JCX	S.M.CAP	50V	47pF	
C1212	ECA1CM470GB	ELECT	16V	47µF	
C1213	ECUV1H103ZFX	S.M.CAP	50V	10nF	
C1214	ECA1CM470GB	ELECT	16V	47µF	
C1215	ECUV1H103ZFX	S.M.CAP	50V	10nF	
C1217	ECUV1H104ZFX	S.M.CAP	50V	100nF	
C1219	ECA1CM471GB	ELECT	16V	470pF	
C1220	ECUV1H103ZFX	S.M.CAP	50V	10nF	
C1221	ECA0JM102GB	ELECT	6.3V	1nF	
C1222	ECUV1H104ZFX	S.M.CAP	50V	100nF	
C1223	ECA1HM101GB	ELECT	50V	100pF	
C1224	ECA0JM222GB	ELECT	6.3V	2.2nF	
C1225	ECA0JM472GE	ELECT	6.3V	4.7nF	
C1226	ECA1HM101GB	ELECT	50V	100pF	
C1227	ECA1VM221B	ELECT	35V	220pF	
C1228	ECA1EM101GB	ELECT	25V	1µF	
C2101	ECUV1H223KBX	S.M.CAP	50V	22nF	
C2102	ECUV1H391KBX	S.M.CAP	50V	390pF	
C2103	ECUV1H102KBX	S.M.CAP	50V	1nF	
C2104	ECUV1H102KBX	S.M.CAP	50V	1nF	
C2107	ECUV1H391KBX	S.M.CAP	50V	390pF	
C2108	ECA1HM101GB	ELECT	50V	100pF	
C2109	ECUV1H223KBX	S.M.CAP	50V	22nF	
C2110	ECA1CM100GB	ELECT	16V	10pF	
C2111	ECUV1H104ZFX	S.M.CAP	50V	100nF	
C2112	ECA1CM100GB	ELECT	16V	10pF	
C2113	ECUV1H102KBX	S.M.CAP	50V	1nF	
C2114	ECUV1H104ZFX	S.M.CAP	50V	100nF	
C2115	ECUV1H471KBX	S.M.CAP	50V	470pF	
C2116	ECA1HM3R3GB	ELECT	50V	3.3µF	
C2117	ECUV1H471KBX	S.M.CAP	50V	470pF	
C2118	ECUV1H104ZFX	S.M.CAP	50V	100nF	
C2119	ECA1CM100GB	ELECT	16V	10pF	
C2120	ECUV1H104ZFX	S.M.CAP	50V	100nF	
C2121	ECUV1H104ZFX	S.M.CAP	50V	100nF	
C2123	ECA1CM100GB	ELECT	16V	10pF	
C2124	ECUV1H104ZFX	S.M.CAP	50V	100nF	
C2125	ECUV1H010CCX	S.M.CAP	50V	1pF	
C2126	ECUV1H010CCX	S.M.CAP	50V	1pF	
C2127	ECA1CM100GB	ELECT	16V	10pF	
C2128	ECUV1H683ZFX	S.M.CAP	50V	68nF	
C2129	ECQM1H334J	FILM	50V	330nF	
C2307	ECA1CM470GB	ELECT	16V	47µF	
C2308	ECA1CM470GB	ELECT	16V	47µF	
C2310	ECA1CM470GB	ELECT	16V	47µF	
C2312	ECUV1H104ZFX	S.M.CAP	50V	100nF	
C2313	ECUV1H103KBX	S.M.CAP	50V	10nF	
C2314	ECUV1H104ZFX	S.M.CAP	50V	100nF	
C2315	ECUV1H103KBX	S.M.CAP	50V	10nF	
C2316	ECUV1H103ZFX	S.M.CAP	50V	10nF	
C2317	ECA1CM470GB	ELECT	16V	47µF	
C2318	ECUV1H222KBX	S.M.CAP	50V	2.2nF	

Ref No.	Part No.	Description
C2319	ECUV1H222KBX	S.M.CAP 50V 2.2nF
C2651	ECUV1H103KBX	S.M.CAP 50V 10nF
C2652	ECUV1H103KBX	S.M.CAP 50V 10nF
C3001	ECA1HMR47GB	ELECT 50V 0.47µF
C3002	ECA1HMR47GB	ELECT 50V 0.47µF
C3003	ECA1EM4R7GB	ELECT 25V 4.7µF
C3004	ECA1HM4R7GB	ELECT 50V 4.7µF
C3005	ECA1HM4R7GB	ELECT 50V 4.7µF
C3006	ECUV1H473ZFX	S.M.CAP 50V 47nF
C3007	ECA1HM470GB	ELECT 50V 47µF
C3011	ECUV1H473ZFX	S.M.CAP 50V 47nF
C3012	ECA1CM470GB	ELECT 16V 47µF
C3013	ECUV1H104ZFX	S.M.CAP 50V 100nF
C3014	ECUV1H104ZFX	S.M.CAP 50V 100nF
C3017	ECEA1CN470	ELECT 16V 47µF
C3018	ECUV1H102KBX	S.M.CAP 50V 1nF
C3019	ECUV1H102KBX	S.M.CAP 50V 1nF
C3020	ECCR1H120J	CERAMIC 50V 12pF
C3021	ECUV1H102KBX	S.M.CAP 50V 1nF
C3023	ECA1CM470GB	ELECT 16V 47µF
C3024	ECUV1H473ZFX	S.M.CAP 50V 47nF
C3025	ECUV1H102KBX	S.M.CAP 50V 1nF
C3026	ECA1CM470GB	ELECT 16V 47µF
C3027	ECA1CM470GB	ELECT 16V 47µF
C3028	ECUV1H221JX	S.M.CAP 50V 220pF
C3029	ECUV1H221JX	S.M.CAP 50V 220pF
C3030	ECUV1H221JX	S.M.CAP 50V 220pF
C3031	ECUV1H221JX	S.M.CAP 50V 220pF
C3032	ECA1HMR47GB	ELECT 50V 0.47µF
C3033	ECA1HMR47GB	ELECT 50V 0.47µF
C3034	ECUV1H221JX	S.M.CAP 50V 220pF
C3035	ECUV1H221JX	S.M.CAP 50V 220pF
C3036	ECUV1H222KBX	S.M.CAP 50V 2.2nF
C3037	ECUV1H561JCX	S.M.CAP 50V 560pF
C3038	ECA1CM470GB	ELECT 16V 47µF
C3039	ECA1CM470GB	ELECT 16V 47µF
C3040	ECA1HMR47GB	ELECT 50V 0.47µF
C3041	ECA1HMR47GB	ELECT 50V 0.47µF
C3043	ECA1HM4R7GB	ELECT 50V 4.7µF
C3045	ECUV1H104ZFX	S.M.CAP 50V 100nF
C3049	ECUV1H222KBX	S.M.CAP 50V 2.2nF
C3050	ECUV1H222KBX	S.M.CAP 50V 2.2nF
C3051	ECUV1H222KBX	S.M.CAP 50V 2.2nF
C3052	ECUV1H222KBX	S.M.CAP 50V 2.2nF
C3053	ECUV1H222KBX	S.M.CAP 50V 2.2nF
C3054	ECUV1H222KBX	S.M.CAP 50V 2.2nF
C3055	ECUV1H222KBX	S.M.CAP 50V 2.2nF
C3056	ECUV1H101JCX	S.M.CAP 50V 100pF
C3062	ECUV1H104ZFX	S.M.CAP 50V 100nF
C3071	ECUV1H104ZFX	S.M.CAP 50V 100nF
C3151	ECUV1H561JCX	S.M.CAP 50V 560pF
C3152	ECUV1H561JCX	S.M.CAP 50V 560pF
C3501	ECUV1H104ZFX	S.M.CAP 50V 100nF
C3502	ECA1HM101GB	ELECT 50V 100pF
C3503	ECUV1H103ZFX	S.M.CAP 50V 10nF
C3504	ECUV1H102JCX	S.M.CAP 50V 1nF
C3505	ECUV1H104ZFX	S.M.CAP 50V 100nF
C3506	ECA1CM470GB	ELECT 16V 47µF
C3507	ECA1CM470GB	ELECT 16V 47µF
C3508	ECUV1H473ZFX	S.M.CAP 50V 47nF
C3509	ECUV1H103ZFX	S.M.CAP 50V 10nF
C3510	ECAOJM102GB	ELECT 6.3V 1nF
C3511	ECUV1H103ZFX	S.M.CAP 50V 10nF

## DIODES

D140	MA3020TX	DIODE
D141	MA3020TX	DIODE
D251	MA2180TP	DIODE
D253	RB721Q40T77	DIODE
D254	RB721Q40T77	DIODE
D310	MA165TA5	DIODE 1SS133T-77

Ref No.	Part No.	Description
D311	MA29TA5	DIODE
D312	MA29TA5	DIODE
D354	ERA22-04V1	DIODE
D355	ERA22-04V1	DIODE
D356	ERA22-04V1	DIODE
D357	MA165TA5	DIODE 1SS133T-77
D358	MA165TA5	DIODE 1SS133T-77
D359	MA165TA5	DIODE 1SS133T-77
D360	MA4150	DIODE
D451	MA165TA5	DIODE 1SS133T-77
D452	MA165TA5	DIODE 1SS133T-77
D454	ERA15-02V3	DIODE
D456	MA2160BLFS	DIODE
D470	MA4020	DIODE
D501	MA165TA5	DIODE 1SS133T-77
D502	EU02	DIODE
D551	ERD07-15L7	DIODE
D552	TVSRU2AM	DIODE
D554	AU02V0	DIODE
D556	MA165TA5	DIODE 1SS133T-77
D601	MA165TA5	DIODE 1SS133T-77
D602	MA165TA5	DIODE 1SS133T-77
D604	MA165TA5	DIODE 1SS133T-77
D605	MA165TA5	DIODE 1SS133T-77
D606	MA165TA5	DIODE 1SS133T-77
D609	MA165TA5	DIODE 1SS133T-77
D701	MA165TA5	DIODE 1SS133T-77
D702	MTZJT-775.6C	DIODE
D804	ERA15-02V3	DIODE
D805	EU02	DIODE
D806	RBV4-08	DIODE
D807	EU02	DIODE
D809	MA165TA5	DIODE 1SS133T-77
D814	MA165TA5	DIODE 1SS133T-77
D851	EU02	DIODE
D852	ERD32-02L7	DIODE
D853	FML22SLF610	DIODE
D854	RU4AMLf-M1	DIODE
D855	RU4BLf-L1	DIODE
D856	MTZJT-775.1A	DIODE
D857	MTZJ33B	DIODE
D858	MA29TA5	DIODE
D1201	SLR56UR3FLF	LED
D1203	MA170	DIODE
D1205	MA165TA5	DIODE 1SS133T-77
D1207	MA165TA5	DIODE 1SS133T-77
D1208	MA165TA5	DIODE 1SS133T-77
D1209	MA165TA5	DIODE 1SS133T-77
D1211	MTZJT-775.1C	DIODE
D1212	MA170	DIODE
D1213	MA165TA5	DIODE 1SS133T-77
D1214	MA170	DIODE
D1216	MTZJT-778.2C	DIODE
D2303	MA165TA5	DIODE 1SS133T-77
D2304	MTZJT-779.1C	DIODE
D3001	MTZJT-7712C	DIODE
D3003	MTZJT-778.2C	DIODE
D3004	MA4100	DIODE
D3005	MTZJT-7712C	DIODE
D3006	MTZJT-7712C	DIODE
D3007	MTZJT-7712C	DIODE
D3008	MTZJT-778.2C	DIODE
D3009	MTZJT-778.2C	DIODE
D3010	MTZJT-778.2C	DIODE
D3011	MTZJT-778.2C	DIODE
D3012	MTZJT-7712C	DIODE
D3013	MTZJT-7712C	DIODE
D3014	MTZJT-7712C	DIODE
D3015	MTZJT-7712C	DIODE
D3016	MTZJT-7712C	DIODE
D3018	MA165TA5	DIODE 1SS133T-77

Ref No.	Part No.	Description			
D3019	MA165TA5	DIODE 1SS133T-77			
D3501	MA165TA5	DIODE 1SS133T-77			
<b>FUSES</b>					
F840	2153.15H	FUSE		△	
F851	TR5-T1250	FUSE		△	
F852	TR5-T2000	FUSE		△	
F853	TR5-T2000	FUSE		△	
F8401	EYF52BC	FUSE HOLDER			
F8402	EYF52BC	FUSE HOLDER			
<b>SOCKETS</b>					
H1202	832AG11D-ESL	I.C.SOCKET			
<b>INTEGRATED CIRCUITS</b>					
IC100	TSA5514AT/C2	A.F.C.CONTROL			
IC103	L78M09MRB	9V REGULATOR			
IC1051	RPM-637CBRL	LED RECEIVER			
IC1201	CCU3000I-07	MICRO-PROCESSOR			
IC1202	27C010-006AE	EPROM			
IC1203	X24LM0401EY	EAROM			
IC1205	MN1280R	RESET			
IC2101	MSP3410BPPF7	AUDIO PROCESSOR			
IC2301	AN78L08TA	8V REGULATOR			
IC251	LA4280-TV	AUDIO OUTPUT			
IC3001	TEA6415C	VIDEO SWITCH			
IC3501	UD61256DC-08	DYNAMIC RAM			
IC3502	TPU3040-20	TEXT PROCESSOR			
IC351	TDA6103Q-N3	R.G.B.AMPLIFIER			
IC451	LA7845N	VERTICAL OUTPUT			
IC601	VDP3108APPA1	VIDEO PROCESSOR			
IC701	TEA2031A	HORIZONTAL OUTPUT			
IC801	TDA4601	POWER SUPPLY			
IC851	L78M12MRB	12V REGULATOR			
<b>TERMINALS AND LINKS</b>					
JA.1	ERJ8GEY0R00	S.M.CAR .125W	5%	0Ω	
JA.10	ERJ6GEY0R00	S.M.CARB 0.1W	5%	0Ω	
JA.11	ERJ8GEY0R00	S.M.CAR .125W	5%	0Ω	
JA.12	ERJ8GEY0R00	S.M.CAR .125W	5%	0Ω	
JA.13	ERJ6GEY0R00	S.M.CARB 0.1W	5%	0Ω	
JA.14	ERJ8GEY0R00	S.M.CAR .125W	5%	0Ω	
JA.15	ERJ8GEY0R00	S.M.CAR .125W	5%	0Ω	
JA.16	ERJ8GEY0R00	S.M.CAR .125W	5%	0Ω	
JA.17	ERJ8GEY0R00	S.M.CAR .125W	5%	0Ω	
JA.18	ERJ6GEY0R00	S.M.CARB 0.1W	5%	0Ω	
JA.19	ERJ6GEY0R00	S.M.CARB 0.1W	5%	0Ω	
JA.2	ERJ8GEY0R00	S.M.CAR .125W	5%	0Ω	
JA.20	ERJ6GEY0R00	S.M.CARB 0.1W	5%	0Ω	
JA.21	ERJ6GEY0R00	S.M.CARB 0.1W	5%	0Ω	
JA.22	ERJ8GEY0R00	S.M.CAR .125W	5%	0Ω	
JA.24	ERJ6GEY0R00	S.M.CARB 0.1W	5%	0Ω	
JA.25	ERJ8GEY0R00	S.M.CAR .125W	5%	0Ω	
JA.26	ERJ6GEY0R00	S.M.CARB 0.1W	5%	0Ω	
JA.27	ERJ6GEY0R00	S.M.CARB 0.1W	5%	0Ω	
JA.28	ERJ6GEY0R00	S.M.CARB 0.1W	5%	0Ω	
JA.29	ERJ6GEY0R00	S.M.CARB 0.1W	5%	0Ω	
JA.3	ERJ8GEY0R00	S.M.CAR .125W	5%	0Ω	
JA.30	ERJ6GEY0R00	S.M.CARB 0.1W	5%	0Ω	
JA.4	ERJ8GEY0R00	S.M.CAR .125W	5%	0Ω	
JA.5	ERJ6GEY0R00	S.M.CARB 0.1W	5%	0Ω	
JA.6	ERJ8GEY0R00	S.M.CAR .125W	5%	0Ω	
JA.7	ERJ8GEY0R00	S.M.CAR .125W	5%	0Ω	
JA.8	ERJ6GEY0R00	S.M.CARB 0.1W	5%	0Ω	
JA.9	ERJ6GEY0R00	S.M.CARB 0.1W	5%	0Ω	
JA33	ERJ8GEY0R00	S.M.CAR .125W	5%	0Ω	
JA34	ERJ6GEY0R00	S.M.CARB 0.1W	5%	0Ω	

Ref No.	Part No.	Description			
JA35	ERJ8GEY0R00	S.M.CAR .125W	5%	0Ω	
JA36	ERJ6GEY0R00	S.M.CARB 0.1W	5%	0Ω	
JB1	ERJ6GEY0R00	S.M.CARB 0.1W	5%	0Ω	
JB10	ERJ6GEY0R00	S.M.CARB 0.1W	5%	0Ω	
JB11	ERJ6GEY0R00	S.M.CARB 0.1W	5%	0Ω	
JB12	ERJ6GEY0R00	S.M.CARB 0.1W	5%	0Ω	
JB13	ERJ6GEY0R00	S.M.CARB 0.1W	5%	0Ω	
JB14	ERJ6GEY0R00	S.M.CARB 0.1W	5%	0Ω	
JB15	ERJ6GEY0R00	S.M.CARB 0.1W	5%	0Ω	
JB16	ERJ6GEY0R00	S.M.CARB 0.1W	5%	0Ω	
JB17	ERJ6GEY0R00	S.M.CARB 0.1W	5%	0Ω	
JB18	ERJ6GEY0R00	S.M.CARB 0.1W	5%	0Ω	
JB19	ERJ6GEY0R00	S.M.CARB 0.1W	5%	0Ω	
JB2	ERJ6GEY0R00	S.M.CARB 0.1W	5%	0Ω	
JB20	ERJ6GEY0R00	S.M.CARB 0.1W	5%	0Ω	
JB21	ERJ6GEY0R00	S.M.CARB 0.1W	5%	0Ω	
JB22	ERJ6GEY0R00	S.M.CARB 0.1W	5%	0Ω	
JB23	ERJ6GEY0R00	S.M.CARB 0.1W	5%	0Ω	
JB24	ERJ6GEY0R00	S.M.CARB 0.1W	5%	0Ω	
JB25	ERJ6GEY0R00	S.M.CARB 0.1W	5%	0Ω	
JB26	ERJ6GEY0R00	S.M.CARB 0.1W	5%	0Ω	
JB27	ERJ6GEY0R00	S.M.CARB 0.1W	5%	0Ω	
JB28	ERJ6GEY0R00	S.M.CARB 0.1W	5%	0Ω	
JB29	ERJ6GEY0R00	S.M.CARB 0.1W	5%	0Ω	
JB3	ERJ6GEY0R00	S.M.CARB 0.1W	5%	0Ω	
JB30	ERJ6GEY0R00	S.M.CARB 0.1W	5%	0Ω	
JB31	ERJ6GEY0R00	S.M.CARB 0.1W	5%	0Ω	
JB32	ERJ6GEY0R00	S.M.CARB 0.1W	5%	0Ω	
JB33	ERJ6GEY0R00	S.M.CARB 0.1W	5%	0Ω	
JB34	ERJ6GEY0R00	S.M.CARB 0.1W	5%	0Ω	
JB35	ERJ6GEY0R00	S.M.CARB 0.1W	5%	0Ω	
JB36	ERJ6GEY0R00	S.M.CARB 0.1W	5%	0Ω	
JB37	ERJ6GEY0R00	S.M.CARB 0.1W	5%	0Ω	
JB38	ERJ6GEY0R00	S.M.CARB 0.1W	5%	0Ω	
JB39	ERJ6GEY0R00	S.M.CARB 0.1W	5%	0Ω	
JB40	ERJ6GEY0R00	S.M.CARB 0.1W	5%	0Ω	
JB41	ERJ6GEY0R00	S.M.CARB 0.1W	5%	0Ω	
JB42	ERJ6GEY0R00	S.M.CARB 0.1W	5%	0Ω	
JB43	ERJ6GEY0R00	S.M.CARB 0.1W	5%	0Ω	
JB44	ERJ6GEY0R00	S.M.CARB 0.1W	5%	0Ω	
JB45	ERJ6GEY0R00	S.M.CARB 0.1W	5%	0Ω	
JB46	ERJ6GEY0R00	S.M.CARB 0.1W	5%	0Ω	
JB47	ERJ6GEY0R00	S.M.CARB 0.1W	5%	0Ω	
JB48	ERJ6GEY0R00	S.M.CARB 0.1W	5%	0Ω	
JB49	ERJ6GEY0R00	S.M.CARB 0.1W	5%	0Ω	
JB50	ERJ6GEY0R00	S.M.CARB 0.1W	5%	0Ω	
JB51	ERJ6GEY0R00	S.M.CARB 0.1W	5%	0Ω	
JB52	ERJ6GEY0R00	S.M.CARB 0.1W	5%	0Ω	
JB53	ERJ6GEY0R00	S.M.CARB 0.1W	5%	0Ω	
JB54	ERJ6GEY0R00	S.M.CARB 0.1W	5%	0Ω	
JB55	ERJ6GEY0R00	S.M.CARB 0.1W	5%	0Ω	
JB56	ERJ6GEY0R00	S.M.CARB 0.1W	5%	0Ω	
JB57	ERJ6GEY0R00	S.M.CARB 0.1W	5%	0Ω	
JB58	ERJ6GEY0R00	S.M.CARB 0.1W	5%	0Ω	
JB59	ERJ6GEY0R00	S.M.CARB 0.1W	5%	0Ω	
JB6	ERJ6GEY0R00	S.M.CARB 0.1W	5%	0Ω	
JB61	ERJ6GEY0R00	S.M.CARB 0.1W	5%	0Ω	
JB62	ERJ6GEY0R00	S.M.CARB 0.1W	5%	0Ω	
JB63	ERJ6GEY0R00	S.M.CARB 0.1W	5%	0Ω	
JB64	ERJ6GEY0R00	S.M.CARB 0.1W	5%	0Ω	
JB65	ERJ6GEY0R00	S.M.CARB 0.1W	5%	0Ω	
JB66	ERJ6GEY0R00	S.M.CARB 0.1W	5%	0Ω	
JB67	ERJ6GEY0R00	S.M.CARB 0.1W	5%	0Ω	
JB68	ERJ6GEY0R00	S.M.CARB 0.1W	5%	0Ω	
JB69	ERJ6GEY0R00	S.M.CARB 0.1W	5%	0Ω	
JB7	ERJ6GEY0R00	S.M.CARB 0.1W	5%	0Ω	
JB70	ERJ6GEY0R00	S.M.CARB 0.1W	5%	0Ω	
JB71	ERJ6GEY0R00	S.M.CARB 0.1W	5%	0Ω	
JB72	ERJ6GEY0R00	S.M.CARB 0.1W	5%	0Ω	
JB73	ERJ6GEY0R00	S.M.CARB 0.1W	5%	0Ω	
JB74	ERJ6GEY0R00	S.M.CARB 0.1W	5%	0Ω	
JB75	ERJ6GEY0R00	S.M.CARB 0.1W	5%	0Ω	

Ref No.	Part No.	Description			
JB77	ERJ6GEY0R00	S.M.CARB 0.1W	5%	Ω	
JB79	ERJ6GEY0R00	S.M.CARB 0.1W	5%	Ω	
JB8	ERJ6GEY0R00	S.M.CARB 0.1W	5%	Ω	
JB80	ERJ6GEY0R00	S.M.CARB 0.1W	5%	Ω	
JB81	ERJ6GEY0R00	S.M.CARB 0.1W	5%	Ω	
JB9	ERJ6GEY0R00	S.M.CARB 0.1W	5%	Ω	
JK2301	TJB18644	AV TERMINAL			
JK3001	TJS8E007	21 PIN TERMINAL			
JK3101	TJS8E007	21 PIN TERMINAL			
JK3102	TJB16673	AV TERMINAL			
JSB1	ERJ6GEY0R00	S.M.CARB 0.1W	5%	Ω	
JSB12	ERJ6GEY0R00	S.M.CARB 0.1W	5%	Ω	
JSB13	ERJ6GEY0R00	S.M.CARB 0.1W	5%	Ω	
JSB14	ERJ6GEY0R00	S.M.CARB 0.1W	5%	Ω	
JSB2	ERJ6GEY0R00	S.M.CARB 0.1W	5%	Ω	
JSB4	EXCELSA35T	COIL			
JSE011	ERJ6GEY0R00	S.M.CARB 0.1W	5%	Ω	
JSE012	ERJ6GEY0R00	S.M.CARB 0.1W	5%	Ω	
JSE013	ERJ6GEY0R00	S.M.CARB 0.1W	5%	Ω	
JSE014	ERJ6GEY0R00	S.M.CARB 0.1W	5%	Ω	
JSE015	ERJ6GEY0R00	S.M.CARB 0.1W	5%	Ω	
JSE016	ERJ6GEY0R00	S.M.CARB 0.1W	5%	Ω	
JSE031	ERJ6GEY0R00	S.M.CARB 0.1W	5%	Ω	
JSE032	ERJ6GEY0R00	S.M.CARB 0.1W	5%	Ω	
JSE035	ERJ6GEY0R00	S.M.CARB 0.1W	5%	Ω	
JSE037	ERJ6GEY0R00	S.M.CARB 0.1W	5%	Ω	
J104	EXCELSA35T	COIL			
J106	EXCELSA35T	COIL			
J107	EXCELSA35T	COIL			
J169	EXCELSA35T	COIL			

### COILS

L001	TLT100K991R	COIL			
L003	EXCELSA35T	COIL			
L100	TLT181K991R	COIL			
L111	TLT101K991R	COIL			
L112	EXCELSA35T	COIL			
L113	EXCELSA35T	COIL			
L130	ELESN8R2KA	COIL			
L132	ELESN8R2KA	COIL			
L202	TLT068K991R	COIL			
L251	EXCELSA35T	COIL			
L301	TLT047K991R	COIL			
L302	EXCEMT101BT	COIL			
L303	EXCEMT101BT	COIL			
L304	EXCEMT101BT	COIL			
L552	ELH5L429	COIL			
L601	TLT047K991R	COIL			
L602	EXCELDR35V	COIL			
L603	TLT047K991R	COIL			
L604	EXCELDR35V	COIL			
L606	TLT015K991R	COIL			
L607	EXCELSA35T	COIL			
L701	ELC10D006	COIL			
L801	EXCELSA24T	COIL			
L802	TLT022K991R	COIL			
L804	ELESN4R7KA	COIL			
L805	298-82858002	COIL			
L841	ELF18D490F	COIL			
L851	EXCELDR35V	COIL			
L852	EXCELSA35T	COIL			
L853	ELEIE470KA	COIL			
L854	ELEIN470KA	COIL			
L855	ELEIN470KA	COIL			
L856	ELEIN470KA	COIL			
L1051	TLT331K991R	COIL			
L1201	TLT047K991R	COIL			
L1202	TLT047K991R	COIL			
L1203	TLT047K991R	COIL			
L1204	EXCELDR35V	COIL			
L2101	TLT100K991R	COIL			

Ref No.	Part No.	Description
L2102	TLT039K991R	COIL
L2103	EXCELSA35T	COIL
L2104	EXCELSA35T	COIL
L3151	EXCEMT101BT	COIL
L3152	EXCEMT101BT	COIL
L3153	EXCEMT101BT	COIL
L3154	EXCEMT101BT	COIL
L3155	ELEBT6R8KA	COIL
L3156	ELEBT6R8KA	COIL
L3158	EXCELSA39V	COIL
L3501	EXCELDR35V	COIL
L3502	EXCELDR35V	COIL
L3503	ELESN4R7KA	COIL
L3504	EXCELSA35T	COIL

### TRANSISTORS

Q201	BC847B	TRANSISTOR OR 2SD601ATX
Q202	BC847B	TRANSISTOR OR 2SD601ATX
Q251	2SD1328STX	TRANSISTOR
Q252	2SD1328STX	TRANSISTOR
Q301	BC857B	TRANSISTOR OR 2SB709ATX
Q302	BC847B	TRANSISTOR OR 2SD601ATX
Q303	BC857B	TRANSISTOR OR 2SB709ATX
Q304	BC847B	TRANSISTOR OR 2SD601ATX
Q305	BC857B	TRANSISTOR OR 2SB709ATX
Q306	BC847B	TRANSISTOR OR 2SD601ATX
Q307	BC847B	TRANSISTOR OR 2SD601ATX
Q308	BC847B	TRANSISTOR OR 2SD601ATX
Q309	BC847B	TRANSISTOR OR 2SD601ATX
Q310	BC847B	TRANSISTOR OR 2SD601ATX
Q311	BC847B	TRANSISTOR OR 2SD601ATX
Q351	2SA1767	TRANSISTOR
Q352	2SA1767	TRANSISTOR
Q353	2SA1767	TRANSISTOR
Q451	BC847B	TRANSISTOR OR 2SD601ATX
Q501	BC847B	TRANSISTOR OR 2SD601ATX
Q502	BC847B	TRANSISTOR OR 2SD601ATX
Q503	2SD836-AL	TRANSISTOR
Q504	BC847B	TRANSISTOR OR 2SD601ATX
Q551	BU2506DXLB	TRANSISTOR
Q552	2SC1473-RN	TRANSISTOR
Q701	BC857B	TRANSISTOR OR 2SB709ATX
Q802	S2000NLBMA	TRANSISTOR
Q851	2SD1273PLB	TRANSISTORALT 2SD2396/JM3
Q852	TFD312SOF632	DIODE
Q1202	BC847B	TRANSISTOR OR 2SD601ATX
Q1205	BC847B	TRANSISTOR OR 2SD601ATX
Q1206	BC847B	TRANSISTOR OR 2SD601ATX
Q1207	BC847B	TRANSISTOR OR 2SD601ATX
Q1208	BC857B	TRANSISTOR OR 2SB709ATX
Q1211	BC547B	TRANSISTOR
Q1212	BC847B	TRANSISTOR OR 2SD601ATX
Q1213	BC847B	TRANSISTOR OR 2SD601ATX
Q2101	BC860B	TRANSISTOR
Q2102	BC860B	TRANSISTOR
Q2301	BC857B	TRANSISTOR OR 2SB709ATX
Q2302	BC857B	TRANSISTOR OR 2SB709ATX
Q2305	2SD1328STX	TRANSISTOR
Q2306	2SD1328STX	TRANSISTOR
Q2307	BC860B	TRANSISTOR
Q2308	BC857B	TRANSISTOR OR 2SB709ATX
Q2309	BC860B	TRANSISTOR
Q2310	BC860B	TRANSISTOR
Q3001	2SC1318-S	TRANSISTOR
Q3004	BC847B	TRANSISTOR OR 2SD601ATX
Q3005	BC847B	TRANSISTOR OR 2SD601ATX
Q3006	2SC1318-S	TRANSISTOR
Q3011	BC857B	TRANSISTOR OR 2SB709ATX
Q3012	2SD1328STX	TRANSISTOR
Q3013	2SD1328STX	TRANSISTOR

Ref No.	Part No.	Description			
<b>RESISTOR</b>					
RL1201	TSE1885-1	TRANSISTOR			
R.604	ERJ6GEY0R00	S.M.CARB	0.1W	5%	0Ω
R.622	ERJ6GEY0R00	S.M.CARB	0.1W	5%	0Ω
R100	ERJ6GEYJ103	S.M.CARB	0.1W	5%	10KΩ
R101	ERJ6GEYJ331	S.M.CARB	0.1W	5%	330Ω
R102	ERJ6GEYJ103	S.M.CARB	0.1W	5%	10KΩ
R103	ERJ6GEYJ331	S.M.CARB	0.1W	5%	330Ω
R107	ERJ6GEYJ103	S.M.CARB	0.1W	5%	10KΩ
R109	ERJ6GEYJ103	S.M.CARB	0.1W	5%	10KΩ
R112	ERJ6GEY0R00	S.M.CARB	0.1W	5%	0Ω
R114	ERJ6GEYJ223	S.M.CARB	0.1W	5%	22KΩ
R117	ERJ6GEYJ103	S.M.CARB	0.1W	5%	10KΩ
R130	ERJ6GEYJ101	S.M.CARB	0.1W	5%	100Ω
R131	ERJ6GEYJ101	S.M.CARB	0.1W	5%	100Ω
R132	ERJ6GEYJ223	S.M.CARB	0.1W	5%	22KΩ
R133	ERJ6GEYJ101	S.M.CARB	0.1W	5%	100Ω
R134	ERJ6GEY0R00	S.M.CARB	0.1W	5%	0Ω
R136	ERJ6GEYJ393	S.M.CARB	0.1W	5%	39KΩ
R138	ERJ6GEYJ103	S.M.CARB	0.1W	5%	10KΩ
R201	ERJ6GEYJ471	S.M.CARB	0.1W	5%	470Ω
R203	ERJ6GEY0R00	S.M.CARB	0.1W	5%	0Ω
R204	ERJ6GEYJ102	S.M.CARB	0.1W	5%	1KΩ
R205	ERJ6GEYJ391	S.M.CARB	0.1W	5%	390Ω
R206	ERJ6GEYJ680	S.M.CARB	0.1W	5%	68Ω
R207	ERJ6GEYJ123	S.M.CARB	0.1W	5%	12KΩ
R208	ERJ6GEYJ182	S.M.CARB	0.1W	5%	1K8Ω
R210	ERJ6GEY0R00	S.M.CARB	0.1W	5%	0Ω
R251	ERJ6GEYJ181	S.M.CARB	0.1W	5%	180Ω
R252	ERJ6GEYJ222	S.M.CARB	0.1W	5%	2K2Ω
R253	ERJ6GEYJ103	S.M.CARB	0.1W	5%	10KΩ
R254	ERJ6GEYJ181	S.M.CARB	0.1W	5%	180Ω
R255	ERJ6GEYJ103	S.M.CARB	0.1W	5%	10KΩ
R256	ERJ6GEYJ471	S.M.CARB	0.1W	5%	470Ω
R257	ERJ6GEYJ560	S.M.CARB	0.1W	5%	56Ω
R258	ERJ6GEYJ222	S.M.CARB	0.1W	5%	2K2Ω
R259	ERJ6GEYJ560	S.M.CARB	0.1W	5%	56Ω
R260	ERJ6GEYJ103	S.M.CARB	0.1W	5%	10KΩ
R261	ERJ6GEYJ471	S.M.CARB	0.1W	5%	470Ω
R262	ERJ6GEYJ103	S.M.CARB	0.1W	5%	10KΩ
R265	ERD25TJ2R2	CARBON	0.25W	5%	2R2Ω
R266	ERD25TJ2R2	CARBON	0.25W	5%	2R2Ω
R267	ERF7ZK4R7	WOUND	7W	10%	4R7Ω
R271	ERJ6GEYJ103	S.M.CARB	0.1W	5%	10KΩ
R272	ERF7ZK5R6	WOUND	7W	10%	5R6Ω
R273	ERD25TJ273	CARBON	0.25W	5%	27KΩ
R301	ERJ6GEYJ750	S.M.CARB	0.1W	5%	75Ω
R302	ERJ6GEYJ471	S.M.CARB	0.1W	5%	470Ω
R303	ERJ6GEYJ471	S.M.CARB	0.1W	5%	470Ω
R304	ERJ6GEYJ471	S.M.CARB	0.1W	5%	470Ω
R305	ERJ6GEYJ750	S.M.CARB	0.1W	5%	75Ω
R306	ERJ6GEYJ471	S.M.CARB	0.1W	5%	470Ω
R307	ERJ6GEYJ471	S.M.CARB	0.1W	5%	470Ω
R308	ERJ6GEYJ471	S.M.CARB	0.1W	5%	470Ω
R309	ERJ6GEYJ750	S.M.CARB	0.1W	5%	75Ω
R310	ERJ6GEYJ471	S.M.CARB	0.1W	5%	470Ω
R311	ERJ6GEYJ471	S.M.CARB	0.1W	5%	470Ω
R312	ERJ6GEYJ471	S.M.CARB	0.1W	5%	470Ω
R313	ERJ6GEYJ101	S.M.CARB	0.1W	5%	100Ω
R314	ERJ6GEYJ332	S.M.CARB	0.1W	5%	3K3Ω
R315	ERJ6GEYJ332	S.M.CARB	0.1W	5%	3K3Ω
R316	ERJ6GEYJ332	S.M.CARB	0.1W	5%	3K3Ω
R321	ERJ6GEYJ473	S.M.CARB	0.1W	5%	47KΩ
R322	ERJ6GEYJ473	S.M.CARB	0.1W	5%	47KΩ
R323	ERJ6GEYJ103	S.M.CARB	0.1W	5%	10KΩ
R324	ERJ6GEYJ104	S.M.CARB	0.1W	5%	100KΩ
R351	ERJ6GEYJ182	S.M.CARB	0.1W	5%	1K8Ω
R352	ERJ6GEYJ182	S.M.CARB	0.1W	5%	1K8Ω
R353	ERJ6GEYJ182	S.M.CARB	0.1W	5%	1K8Ω
R354	ERJ6GEYJ102	S.M.CARB	0.1W	5%	1KΩ
R355	ERJ6GEYJ102	S.M.CARB	0.1W	5%	1KΩ

Ref No.	Part No.	Description			
R356	ERJ6GEYJ102	S.M.CARB	0.1W	5%	1KΩ
R357	ERG1FJ563	METAL	1W	5%	56KΩ
R358	ERG2FJ563	METAL	2W	5%	56KΩ
R359	ERG1FJ563	METAL	1W	5%	56KΩ
R363	ERDS1TJ103	CARBON	0.5W	5%	10KΩ
R364	ERDS1TJ103	CARBON	0.5W	5%	10KΩ
R365	ERDS1TJ103	CARBON	0.5W	5%	10KΩ
R366	ERDS1TJ222	CARBON	0.5W	5%	2K2Ω
R367	ERDS1TJ222	CARBON	0.5W	5%	2K2Ω
R368	ERDS1TJ222	CARBON	0.5W	5%	2K2Ω
R369	ERD25TJ223	CARBON	0.25W	5%	22KΩ
R370	ERD25TJ103	CARBON	0.25W	5%	10KΩ
R372	ERQ12AJ121	FUSIBLE	0.5W	5%	120Ω
R373	ERJ6GEYJ220	S.M.CARB	0.1W	5%	22Ω
R374	ERDS1TJ274	CARBON	0.5W	5%	270KΩ
R375	ERJ6GEYJ684	S.M.CARB	0.1W	5%	680KΩ
R376	ERJ6GEYJ183	S.M.CARB	0.1W	5%	18KΩ
R377	ERQ12HJ1R2	METAL	0.5W	5%	1R2Ω
R378	ERJ6GEY0R00	S.M.CARB	0.1W	5%	0Ω
R379	ERJ6GEY0R00	S.M.CARB	0.1W	5%	0Ω
R380	ERJ6GEY0R00	S.M.CARB	0.1W	5%	0Ω
R451	ERJ6GEYJ273	S.M.CARB	0.1W	5%	27KΩ
R452	ERJ6GEYJ472	S.M.CARB	0.1W	5%	4K7Ω
R453	ERJ6GEYJ104	S.M.CARB	0.1W	5%	100KΩ
R455	ERJ6GEYJ222	S.M.CARB	0.1W	5%	2K2Ω
R456	ERJ6GEYJ123	S.M.CARB	0.1W	5%	12KΩ
R457	ERJ6GEYJ103	S.M.CARB	0.1W	5%	10KΩ
R458	ERD25TJ1R5	CARBON	0.25W	5%	1R5Ω
R459	ERJ6GEYJ680	S.M.CARB	0.1W	5%	68Ω
R460	ERJ6GEYJ513	S.M.CARB	0.1W	5%	51KΩ
R461	ERDS1TJ471	CARBON	0.5W	5%	470Ω
R462	ERJ6GEYJ472	S.M.CARB	0.1W	5%	4K7Ω
R463	ERJ6GEYJ472	S.M.CARB	0.1W	5%	4K7Ω
R464	ERW12PK1R5	WIRE	12W	10%	1R5Ω
R465	ERJ6GEYJ101	S.M.CARB	0.1W	5%	100Ω
R466	ERO25CKF1801	METAL	0.25W	1%	1K8Ω
R467	ERO25CKF1201	METAL	0.25W	1%	1K2Ω
R470	ERD25TJ512	CARBON	0.25W	5%	5K1Ω
R471	ERDS1TJ152	CARBON	0.5W	5%	1K5Ω
R472	ERDS1TJ4R7	CARBON	0.5W	5%	4R7Ω
R501	ERJ6GEYJ331	S.M.CARB	0.1W	5%	330Ω
R502	ERJ6GEYJ560	S.M.CARB	0.1W	5%	56Ω
R503	ERJ6GEYJ273	S.M.CARB	0.1W	5%	27KΩ
R504	ERJ6GEYJ101	S.M.CARB	0.1W	5%	100Ω
R506	ERD25TJ560	CARBON	0.25W	5%	56Ω
R507	ERQ14AJW3R3	FUSIBLE	0.25W	5%	3R3Ω
R509	ERDS1TJ152	CARBON	0.5W	5%	1K5Ω
R510	ERDS1TJ152	CARBON	0.5W	5%	1K5Ω
R511	ERJ6GEYJ104	S.M.CARB	0.1W	5%	100KΩ
R512	ERJ6GEYJ472	S.M.CARB	0.1W	5%	4K7Ω
R513	ERJ6GEYJ123	S.M.CARB	0.1W	5%	12KΩ
R514	ERJ6GEYJ123	S.M.CARB	0.1W	5%	12KΩ
R551	ERW2PKR47	WIREWOUND	2W	10%	0R47Ω
R553	ERG1SJ152	METAL	1W	5%	1K5Ω
R558	ERDS1TJ124	CARBON	0.5W	5%	120KΩ
R561	ERJ6GEYJ563	S.M.CARB	0.1W	5%	56KΩ
R562	ERJ6GEYJ225	SM.CARB0.125W		5%	2.2MΩ
R563	ERJ6GEYJ225	SM.CARB0.125W		5%	2.2MΩ
R564	ERJ6GEYJ623	SM.CARB0.125W		5%	62KΩ
R566	ERJ6GEYJ473	S.M.CARB	0.1W	5%	47KΩ
R567	ERJ6GEYJ274	S.M.CARB	0.1W	5%	270KΩ
R601	ERJ6GEYJ151	S.M.CARB	0.1W	5%	150Ω
R602	ERJ6GEYJ151	S.M.CARB	0.1W	5%	150Ω
R603	ERJ6GEYJ750	S.M.CARB	0.1W	5%	75Ω
R605	ERJ6GEYJ183	S.M.CARB	0.1W	5%	18KΩ
R606	ERJ6GEYJ472	S.M.CARB	0.1W	5%	4K7Ω
R607	ERJ6GEYJ103	S.M.CARB	0.1W	5%	10KΩ
R608	ERJ6GEYJ101	S.M.CARB	0.1W	5%	100Ω
R609	ERJ6GEYJ101	S.M.CARB	0.1W	5%	100Ω
R610	ERJ6GEYJ473	S.M.CARB	0.1W	5%	47KΩ
R611	ERJ6GEYJ102	S.M.CARB	0.1W	5%	1KΩ
R612	ERJ6GEYJ123	S.M.CARB	0.1W	5%	12KΩ

Ref No.	Part No.	Description				
R613	ERJ6GEYJ271	S.M.CARB	0.1W	5%	270Ω	
R614	ERJ6GEYJ470	S.M.CARB	0.1W	5%	47Ω	
R615	ERJ6GEYJ333	S.M.CARB	0.1W	5%	33KΩ	
R616	ERJ6GEYJ153	S.M.CARB	0.1W	5%	15KΩ	
R618	ERJ6GEYJ151	S.M.CARB	0.1W	5%	150Ω	
R619	ERJ6GEYJ472	S.M.CARB	0.1W	5%	4K7Ω	
R623	ERJ6GEYJ821	S.M.CARB	0.1W	5%	820Ω	
R701	ERQ12AJ101	FUSIBLE	0.5W	5%	100Ω	Δ
R702	ERQ12HJ330	METAL	0.5W	5%	33Ω	Δ
R703	ERG2FJ821	METAL	2W	5%	820Ω	Δ
R704	ERJ6GEYJ563	S.M.CARB	0.1W	5%	56KΩ	
R705	ERJ6GEYJ104	S.M.CARB	0.1W	5%	100KΩ	
R706	ERJ6GEYJ272	S.M.CARB	0.1W	5%	2K7Ω	
R707	ERJ6GEYJ122	S.M.CARB	0.1W	5%	1K2Ω	
R708	ERJ6GEYJ393	S.M.CARB	0.1W	5%	39KΩ	
R709	ERJ6GEYJ393	S.M.CARB	0.1W	5%	39KΩ	
R710	ERJ6GEYJ273	S.M.CARB	0.1W	5%	27KΩ	
R711	ERJ6GEYJ681	S.M.CARB	0.1W	5%	680Ω	
R712	ERJ6GEYJ472	S.M.CARB	0.1W	5%	4K7Ω	
R713	ERG1SJ101	METAL	1W	5%	100Ω	
R801	ERG3FJ682H	METAL	3W	5%	6K8Ω	Δ
R802	ERG2FJ472	METAL	2W	5%	4K7Ω	Δ
R803	ERX12SJWR47	METAL	12W	5%	R47	
R804	ERJ6GEYJ682	S.M.CARB	0.1W	5%	6K8Ω	
R805	ERJ6GEYJ221	S.M.CARB	0.1W	5%	220Ω	
R807	ERO25CKF1201	METAL	0,25W	1%	1K2Ω	Δ
R808	232266296319	THERMISTOR				
R809	ERO25CKF1302	METAL	0.25W	1%	13KΩ	Δ
R810	ERD25TJ103	CARBON	0.25W	5%	10KΩ	
R811	EVMEASA00B33	CONTROL	3KΩ			
R812	ERDS1TJ220	CARBON	0.5W	5%	22Ω	
R813	ERD50FJ274	CARBON	0.5W	5%	270KΩ	
R814	ERF7ZK2R7	WOUND	7W	20%	2R7Ω	Δ
R815	ERDS1TJ563	CARBON	0.5W	5%	56KΩ	
R817	ERG3FJ470	METAL	3W	5%	47Ω	Δ
R818	ERD50FJ104	CARBON	0.5W	5%	100KΩ	
R819	ERD50FJ184	CARBON	0.5W	5%	180KΩ	
R820	ERD75TAJ825	CARBON	0.75W	5%	8M2Ω	Δ
R841	ERC12ZGK335D	SOLID	0.5W	10%	3M3Ω	
R852	ERJ6GEYJ271	S.M.CARB	0.1W	5%	270Ω	
R853	ERJ6GEYJ101	S.M.CARB	0.1W	5%	100Ω	
R854	ERDS1TJ474	CARBON	0.5W	5%	470KΩ	
R855	ERG2FJ223	METAL	2W	5%	22KΩ	Δ
R856	ERJ6GEYJ102	S.M.CARB	0.1W	5%	1KΩ	
R857	ERG2SJS100H	METAL	2W	2%	10Ω	Δ
R1201	ERJ6GEYJ271	S.M.CARB	0.1W	5%	270Ω	
R1202	ERJ6GEYJ101	S.M.CARB	0.1W	5%	100Ω	
R1203	ERJ6GEYJ101	S.M.CARB	0.1W	5%	100Ω	
R1204	ERJ6GEYJ101	S.M.CARB	0.1W	5%	100Ω	
R1205	ERJ6GEYJ101	S.M.CARB	0.1W	5%	100Ω	
R1206	ERJ6GEYJ101	S.M.CARB	0.1W	5%	100Ω	
R1208	ERJ6GEYJ223	S.M.CARB	0.1W	5%	22KΩ	
R1209	ERJ6GEYJ472	S.M.CARB	0.1W	5%	4K7Ω	
R1210	ERJ6GEYJ472	S.M.CARB	0.1W	5%	4K7Ω	
R1212	ERJ6GEYJ103	S.M.CARB	0.1W	5%	10KΩ	
R1213	ERJ6GEYJ103	S.M.CARB	0.1W	5%	10KΩ	
R1214	ERJ6GEYJ472	S.M.CARB	0.1W	5%	4K7Ω	
R1215	ERJ6GEYJ101	S.M.CARB	0.1W	5%	100Ω	
R1216	ERJ6GEYJ101	S.M.CARB	0.1W	5%	100Ω	
R1217	ERJ6GEYJ101	S.M.CARB	0.1W	5%	100Ω	
R1218	ERJ6GEYJ472	S.M.CARB	0.1W	5%	4K7Ω	
R1219	ERJ6GEYJ472	S.M.CARB	0.1W	5%	4K7Ω	
R1220	ERJ6GEYJ472	S.M.CARB	0.1W	5%	4K7Ω	
R1221	ERJ6GEYJ103	S.M.CARB	0.1W	5%	10KΩ	
R1222	ERJ6GEYJ103	S.M.CARB	0.1W	5%	10KΩ	
R1224	ERJ6GEYJ103	S.M.CARB	0.1W	5%	10KΩ	
R1225	ERJ6GEYJ472	S.M.CARB	0.1W	5%	4K7Ω	
R1226	ERJ6GEYJ472	S.M.CARB	0.1W	5%	4K7Ω	
R1227	ERJ6GEYJ472	S.M.CARB	0.1W	5%	4K7Ω	
R1229	ERJ6GEY0R00	S.M.CARB	0.1W	5%	0Ω	
R1230	ERJ6GEY0R00	S.M.CARB	0.1W	5%	0Ω	
R1231	ERJ6GEYJ472	S.M.CARB	0.1W	5%	4K7Ω	

Ref No.	Part No.	Description				
R1232	ERJ6GEYJ103	S.M.CARB	0.1W	5%	10KΩ	
R1233	ERJ6GEYJ472	S.M.CARB	0.1W	5%	4K7Ω	
R1235	ERJ6GEYJ103	S.M.CARB	0.1W	5%	10KΩ	
R1236	ERJ6GEYJ472	S.M.CARB	0.1W	5%	4K7Ω	
R1237	ERJ6GEYJ103	S.M.CARB	0.1W	5%	10KΩ	
R1238	ERJ6GEYJ393	S.M.CARB	0.1W	5%	39KΩ	
R1239	ERJ6GEYJ392	S.M.CARB	0.1W	5%	3K9Ω	
R1240	ERJ6GEYJ392	S.M.CARB	0.1W	5%	3K9Ω	
R1241	ERJ6GEYJ101	S.M.CARB	0.1W	5%	100Ω	
R1242	ERJ6GEYJ101	S.M.CARB	0.1W	5%	100Ω	
R1244	ERJ6GEY0R00	S.M.CARB	0.1W	5%	0Ω	
R1245	ERJ6GEYJ222	S.M.CARB	0.1W	5%	2K2Ω	
R1246	ERJ6GEYJ103	S.M.CARB	0.1W	5%	10KΩ	
R1247	ERJ6GEYJ103	S.M.CARB	0.1W	5%	10KΩ	
R1249	ERJ6GEYJ472	S.M.CARB	0.1W	5%	4K7Ω	
R1250	ERJ6GEYJ103	S.M.CARB	0.1W	5%	10KΩ	
R1251	ERJ6GEYJ393	S.M.CARB	0.1W	5%	39KΩ	
R1252	ERX1SJ3R3	METAL	1W	5%	3R3Ω	
R1253	ERJ6GEYJ103	S.M.CARB	0.1W	5%	10KΩ	
R1254	ERJ6GEYJ104	S.M.CARB	0.1W	5%	100KΩ	
R1255	ERJ6GEYJ104	S.M.CARB	0.1W	5%	100KΩ	
R1256	ERJ6GEYJ102	S.M.CARB	0.1W	5%	1KΩ	
R1257	ERJ6GEYJ101	S.M.CARB	0.1W	5%	100Ω	
R1258	ERJ6GEYJ472	S.M.CARB	0.1W	5%	4K7Ω	
R1260	ERDS1FJ121	CARBON	0.5W	5%	120Ω	Δ
R1261	ERJ6GEYJ392	S.M.CARB	0.1W	5%	3K9Ω	
R1262	ERJ6GEYJ682	S.M.CARB	0.1W	5%	6K8Ω	
R1263	ERJ6GEYJ223	S.M.CARB	0.1W	5%	22KΩ	
R1264	ERJ6GEYJ222	S.M.CARB	0.1W	5%	2K2Ω	
R1265	ERJ6GEYJ152	S.M.CARB	0.1W	5%	1K5Ω	
R1266	ERJ6GEYJ223	S.M.CARB	0.1W	5%	22KΩ	
R1277	ERDS1TJ151	CARBON	0.5W	5%	150Ω	
R2101	ERJ6GEYJ471	S.M.CARB	0.1W	5%	470Ω	
R2102	ERJ6GEYJ561	S.M.CARB	0.1W	5%	560Ω	
R2103	ERJ6GEYJ471	S.M.CARB	0.1W	5%	470Ω	
R2104	ERJ6GEYJ471	S.M.CARB	0.1W	5%	470Ω	
R2105	ERJ6GEYJ561	S.M.CARB	0.1W	5%	560Ω	
R2106	ERJ6GEYJ183	S.M.CARB	0.1W	5%	18KΩ	
R2107	ERJ6GEYJ471	S.M.CARB	0.1W	5%	470Ω	
R2108	ERJ6GEYJ101	S.M.CARB	0.1W	5%	100Ω	
R2109	ERJ6GEYJ101	S.M.CARB	0.1W	5%	100Ω	
R2110	ERJ6GEYJ103	S.M.CARB	0.1W	5%	10KΩ	
R2111	ERJ6GEYJ102	S.M.CARB	0.1W	5%	1KΩ	
R2301	ERJ6GEYJ222	S.M.CARB	0.1W	5%	2K2Ω	
R2302	ERJ6GEYJ222	S.M.CARB	0.1W	5%	2K2Ω	
R2303	ERJ6GEYJ101	S.M.CARB	0.1W	5%	100Ω	
R2304	ERJ6GEYJ101	S.M.CARB	0.1W	5%	100Ω	
R2313	ERJ6GEYJ101	S.M.CARB	0.1W	5%	100Ω	
R2314	ERJ6GEYJ101	S.M.CARB	0.1W	5%	100Ω	
R2315	ERJ6GEYJ473	S.M.CARB	0.1W	5%	47KΩ	
R2316	ERJ6GEYJ104	S.M.CARB	0.1W	5%	100KΩ	
R2318	ERJ6GEYJ104	S.M.CARB	0.1W	5%	100KΩ	
R2321	ERJ6GEYJ103	S.M.CARB	0.1W	5%	10KΩ	
R2322	ERJ6GEYJ471	S.M.CARB	0.1W	5%	470Ω	
R2323	ERJ6GEYJ103	S.M.CARB	0.1W	5%	10KΩ	
R2324	ERJ6GEYJ471	S.M.CARB	0.1W	5%	470Ω	
R2325	ERJ6GEYJ273	S.M.CARB	0.1W	5%	27KΩ	
R2326	ERJ6GEYJ471	S.M.CARB	0.1W	5%	470Ω	
R2327	ERJ6GEYJ471	S.M.CARB	0.1W	5%	470Ω	
R2328	ERJ6GEYJ473	S.M.CARB	0.1W	5%	47KΩ	
R2329	ERJ6GEYJ222	S.M.CARB	0.1W	5%	2K2Ω	
R2330	ERJ6GEYJ222	S.M.CARB	0.1W	5%	2K2Ω	
R2331	ERJ6GEYJ223	S.M.CARB	0.1W	5%	22KΩ	
R2332	ERJ6GEYJ471	S.M.CARB	0.1W	5%	470Ω	
R2333	ERJ6GEYJ471	S.M.CARB	0.1W	5%	470Ω	
R2334	ERJ6GEY0R00	S.M.CARB	0.1W	5%	0Ω	
R2335	ERJ6GEY0R00	S.M.CARB	0.1W	5%	0Ω	
R2651	ERG2FJ221	METAL	2W	5%	220Ω	Δ
R2652	ERG2FJ221	METAL	2W	5%	220Ω	Δ
R2653	ERDS1TJ151	CARBON	0.5W	5%	150Ω	
R2654	ERDS1TJ151	CARBON	0.5W	5%	150Ω	
R3001	ERJ6GEYJ153	S.M.CARB	0.1W	5%	15KΩ	



Ref No.	Part No.	Description			
R3002	ERJ6GEYJ101	S.M.CARB	0.1W	5%	100Ω
R3003	ERJ6GEYJ101	S.M.CARB	0.1W	5%	100Ω
R3004	ERJ6GEYJ153	S.M.CARB	0.1W	5%	15KΩ
R3005	ERJ6GEYJ470	S.M.CARB	0.1W	5%	47Ω
R3006	ERJ6GEYJ470	S.M.CARB	0.1W	5%	47Ω
R3007	ERJ6GEYJ750	S.M.CARB	0.1W	5%	75Ω
R3008	ERJ6GEYJ104	S.M.CARB	0.1W	5%	100KΩ
R3009	ERJ6GEYJ104	S.M.CARB	0.1W	5%	100KΩ
R3010	ERJ6GEYJ561	S.M.CARB	0.1W	5%	560Ω
R3011	ERJ6GEYJ101	S.M.CARB	0.1W	5%	100Ω
R3012	ERJ6GEYJ101	S.M.CARB	0.1W	5%	100Ω
R3013	ERJ6GEYJ561	S.M.CARB	0.1W	5%	560Ω
R3014	ERJ6GEY0R00	S.M.CARB	0.1W	5%	0Ω
R3015	ERJ6GEY0R00	S.M.CARB	0.1W	5%	0Ω
R3016	ERJ6GEYJ103	S.M.CARB	0.1W	5%	10KΩ
R3017	ERJ6GEYJ102	S.M.CARB	0.1W	5%	1KΩ
R3019	ERJ6GEYJ471	S.M.CARB	0.1W	5%	470Ω
R3020	ERJ6GEYJ103	S.M.CARB	0.1W	5%	10KΩ
R3022	ERD2FCG560	CARBON	2W	2%	56Ω
R3024	ERJ6GEYJ471	S.M.CARB	0.1W	5%	470Ω
R3025	ERJ6GEYJ103	S.M.CARB	0.1W	5%	10KΩ
R3026	ERJ6GEYJ471	S.M.CARB	0.1W	5%	470Ω
R3027	ERJ6GEYJ680	S.M.CARB	0.1W	5%	68Ω
R3029	ERJ6GEYJ680	S.M.CARB	0.1W	5%	68Ω
R3030	ERJ6GEYJ103	S.M.CARB	0.1W	5%	10KΩ
R3032	ERJ6GEYJ680	S.M.CARB	0.1W	5%	68Ω
R3034	ERJ6GEYJ103	S.M.CARB	0.1W	5%	10KΩ
R3036	ERJ6GEYJ220	S.M.CARB	0.1W	5%	22Ω
R3037	ERJ6GEYJ750	S.M.CARB	0.1W	5%	75Ω
R3038	ERD2FCG100	CARB	2W	2%	10Ω
R3039	ERJ6GEYJ101	S.M.CARB	0.1W	5%	100Ω
R3040	ERJ6GEYJ101	S.M.CARB	0.1W	5%	100Ω
R3041	ERJ6GEYJ153	S.M.CARB	0.1W	5%	15KΩ
R3042	ERJ6GEYJ682	S.M.CARB	0.1W	5%	6K8Ω
R3043	ERD2FCG100	CARB	2W	2%	10Ω
R3044	ERJ6GEYJ101	S.M.CARB	0.1W	5%	100Ω
R3045	ERJ6GEYJ471	S.M.CARB	0.1W	5%	470Ω
R3046	ERJ6GEYJ101	S.M.CARB	0.1W	5%	100Ω
R3047	ERJ6GEYJ680	S.M.CARB	0.1W	5%	68Ω
R3048	ERJ6GEYJ102	S.M.CARB	0.1W	5%	1KΩ
R3049	ERJ6GEYJ680	S.M.CARB	0.1W	5%	68Ω
R3050	ERJ6GEYJ101	S.M.CARB	0.1W	5%	100Ω
R3051	ERJ6GEYJ101	S.M.CARB	0.1W	5%	100Ω
R3052	ERJ6GEYJ101	S.M.CARB	0.1W	5%	100Ω
R3053	ERJ6GEYJ101	S.M.CARB	0.1W	5%	100Ω
R3054	ERJ6GEYJ101	S.M.CARB	0.1W	5%	100Ω
R3055	ERJ6GEYJ101	S.M.CARB	0.1W	5%	100Ω
R3056	ERJ6GEYJ101	S.M.CARB	0.1W	5%	100Ω
R3057	ERJ6GEYJ101	S.M.CARB	0.1W	5%	100Ω
R3058	ERJ6GEYJ153	S.M.CARB	0.1W	5%	15KΩ
R3059	ERJ6GEYJ153	S.M.CARB	0.1W	5%	15KΩ
R3060	ERJ6GEYJ470	S.M.CARB	0.1W	5%	47Ω
R3062	ERJ6GEYJ750	S.M.CARB	0.1W	5%	75Ω
R3063	ERJ6GEYJ750	S.M.CARB	0.1W	5%	75Ω
R3064	ERJ6GEYJ103	S.M.CARB	0.1W	5%	10KΩ
R3065	ERJ6GEYJ104	S.M.CARB	0.1W	5%	100KΩ
R3066	ERJ6GEYJ104	S.M.CARB	0.1W	5%	100KΩ
R3067	ERJ6GEYJ273	S.M.CARB	0.1W	5%	27KΩ
R3068	ERJ6GEYJ103	S.M.CARB	0.1W	5%	10KΩ
R3069	ERJ6GEYJ103	S.M.CARB	0.1W	5%	10KΩ
R3070	ERJ6GEYJ750	S.M.CARB	0.1W	5%	75Ω
R3071	ERJ6GEYJ470	S.M.CARB	0.1W	5%	47Ω
R3150	ERJ6GEYJ750	S.M.CARB	0.1W	5%	75Ω
R3151	ERJ6GEYJ750	S.M.CARB	0.1W	5%	75Ω
R3152	ERJ6GEYJ750	S.M.CARB	0.1W	5%	75Ω
R3153	ERJ6GEYJ750	S.M.CARB	0.1W	5%	75Ω
R3154	ERJ6GEYJ183	S.M.CARB	0.1W	5%	18KΩ
R3155	ERJ6GEYJ101	S.M.CARB	0.1W	5%	100Ω
R3156	ERJ6GEYJ101	S.M.CARB	0.1W	5%	100Ω
R3157	ERJ6GEYJ183	S.M.CARB	0.1W	5%	18KΩ
R3158	ERJ6GEYJ750	S.M.CARB	0.1W	5%	75Ω
R3502	ERJ6GEYJ101	S.M.CARB	0.1W	5%	100Ω

Ref No.	Part No.	Description			
R3504	ERJ6GEYJ101	S.M.CARB	0.1W	5%	100Ω
R3505	ERJ6GEY0R00	S.M.CARB	0.1W	5%	0Ω
R3508	ERJ6GEYJ183	S.M.CARB	0.1W	5%	18KΩ
R3511	ERJ6GEYJ103	S.M.CARB	0.1W	5%	10KΩ
R3512	ERJ6GEYJ472	S.M.CARB	0.1W	5%	4K7Ω

### SWITCHES

S801	ESB91232A	SWITCH	
S1201	EVQ23405R	SWITCH	
S1202	EVQ23405R	SWITCH	
S1203	EVQ23405R	SWITCH	
S1204	EVQ23405R	SWITCH	
S1205	EVQ23405R	SWITCH	

△

### TRANSFORMERS

T501	5270103200	TRANSFORMER	
T551	ZTFH44010A	F.B.T.	
T801	TLP8E1003	CHOPPER TRANSFORMER	
T1201	ETP35KAN61ZU	TRANSFORMER	

### FILTERS







X100	EFGA6R5MB3	FILTER	
X601	TSS2169-B	CRYSTAL	
X1201	TSS120M2	CRYSTAL	
X2101	4730007158	CRYSTAL	

# SCHEMATIC DIAGRAM FOR MODEL TX-21AD3F (Euro-2 Chassis)

## IMPORTANT SAFETY NOTICE

Components identified by  mark have special characteristics important for safety. When replacing any of these components, use only manufacturer's specified parts.

## Notes

1. **RESISTOR**  
All resistors are carbon 1/4W resistor, unless marked as follows:  
Unit of resistance is OHM ( $\Omega$ ) (K=1,000, M=1,000,000).
2. **CAPACITORS**  
All capacitors are ceramic 50V, unless marked as follows:  
Unit of capacitance is  $\mu$ F, unless otherwise stated.
3. **COIL**  
Unit of inductance is  $\mu$ H, unless otherwise stated.
4. Components marked 'L' on the schematic diagram shows leadless parts.
5. **TEST POINT**  
 Test Point Position
6. **EARTH SYMBOL**  
 Chassis Earth Cold      Line Earth Hot
7. **VOLTAGE MEASUREMENT**  
Voltage is measured by a DC voltmeter.  
Measurement conditions are as follows:  
Power source                      AC 220V-240V, 50Hz  
Receiving Signal                  Colour Bar signal (RF)  
All customer controls              Maximum position
8.  
 Indicates the video signal path  
 Indicates the Audio signal path  
 Indicates the Vertical/Horizontal path
9. This schematic diagram is the latest at the time of printing and is subject to change without notice.

## Remarks

1. The Power Circuit contains a circuit area which uses a separate power supply to isolate the earth connection. The circuit is defined by HOT and COLD indications in the schematic diagram. All circuits, except the Power Circuit, are COLD. Take the following precautions:

## Precautions







- a. Do not touch the hot part, or the hot and cold parts at the same time, as you are liable to a shock hazard.
- b. Do not short-circuit the hot and cold circuits as electrical components may be damaged.
- c. Do not connect an instrument, such as an oscilloscope, to the hot and cold circuits simultaneously, as this may cause fuse failure. Connect the earth of the instruments to the earth connection of the circuit being measured.
- d. Make sure to disconnect the power plug before removing the chassis.

# ZEICHENERKLÄRUNG FÜR MODELL TX-21AD3F (Euro-2 Chassis)

## WICHTIGER SICHERHEITSHINWEIS

Teile, die mit einem Hinweis  gekennzeichnet sind, sind wichtig für die Sicherheit. Sollte ein Auswechseln erforderlich sein, sind unbedingt Originalteile einzusetzen.

## Anmerkung

1. **WIDERSTÄNDE**  
Alle 1/4Watt Widerstände sind Kohlewiderstände, Abweichungen sind folgt gekennzeichnet.  
Die Maßeinheit ist OHM ( $\Omega$ ) (K=1,000 M=1,000,000)
2. **KONDENSATOREN**  
Alle Kondensatoren sind Keramikausführungen Spannungsfestigkeit 50V. Abweichungen sind wie folgt gekennzeichnet.  
Die Maßeinheit ist  $\mu$ F, wenne keine anderen Bezeichnungen genannt sind.
3. **SPULEN**  
Die Maßeinheit ist  $\mu$ H, Abweichungen sind gekennzeichnet.
4. Mit 'L' gekennzeichnete Teile sind ohne Anschlußdrähte.
5. **TESTPUNKTE**  
 Kennzeichnung der Testpunktposition
6. **MASSE SYMBOL**  
 Erdung am Chassis      Erdung an Masse-Leitung
7. **SPANNUNGSMESSUNG**  
Spannungsmessungen sind mit einem DC-Voltmeter durchzuführen. Die Meßbedingungen sind folgende:  
Netzspannung                      AC 220V-240V 50Hz  
Wiedergabe Signal                  Farbbalken-Testbild  
Alle übrigen Einstellungen für Benutzer     Sollangaben
8.  
 Videosignalweg  
 Audiosignalweg  
 Signalweg für Hor/Vert. Synchronsignale
9. Änderungen im Laufe der Fertigung sind möglich.

## Bemerkungen

1. Das Schaltnetzteil enthält Bereiche, die direkt mit dem Netz verbunden sind. Diese Bereiche sind im Schalplan mit HOT gekennzeichnet. Alle anderen Schaltungen sind mit COLD gekennzeichnet und haben keine direkte Verbindung mit dem Netz.

## Für den netzverbundenen Bereich (HOT) sind folgende Vorsichtsmaßnahmen zu beachten:

- a. Weder die Leitungen im heißen noch Leitungen im kalten Bereich gleichzeitig berühren. Es besteht die Gefahr eines elektrischen Schlages.
- b. Keinesfalls die Leitungen im heißen Bereich mit denen im kalten Bereich verbinden oder kurzschließen. Dies kann zur Zerstörung von Bauteilen oder Sicherungen führen. Außerdem ist die elektrische Betriebssicherheit des Gerätes nicht mehr gegeben.
- c. Keine Messinstrumente gleichzeitig an Leitungen im heißen und kalten Bereich anschließen. Sicherungen könnten zerstört werden. Die Erde des Messinstrumentes immer mit der des zu prüfenden Schaltkreises verbinden.
- d. Vor Ausbau des Chassis, Stecker aus der Netzsteckdose ziehen.

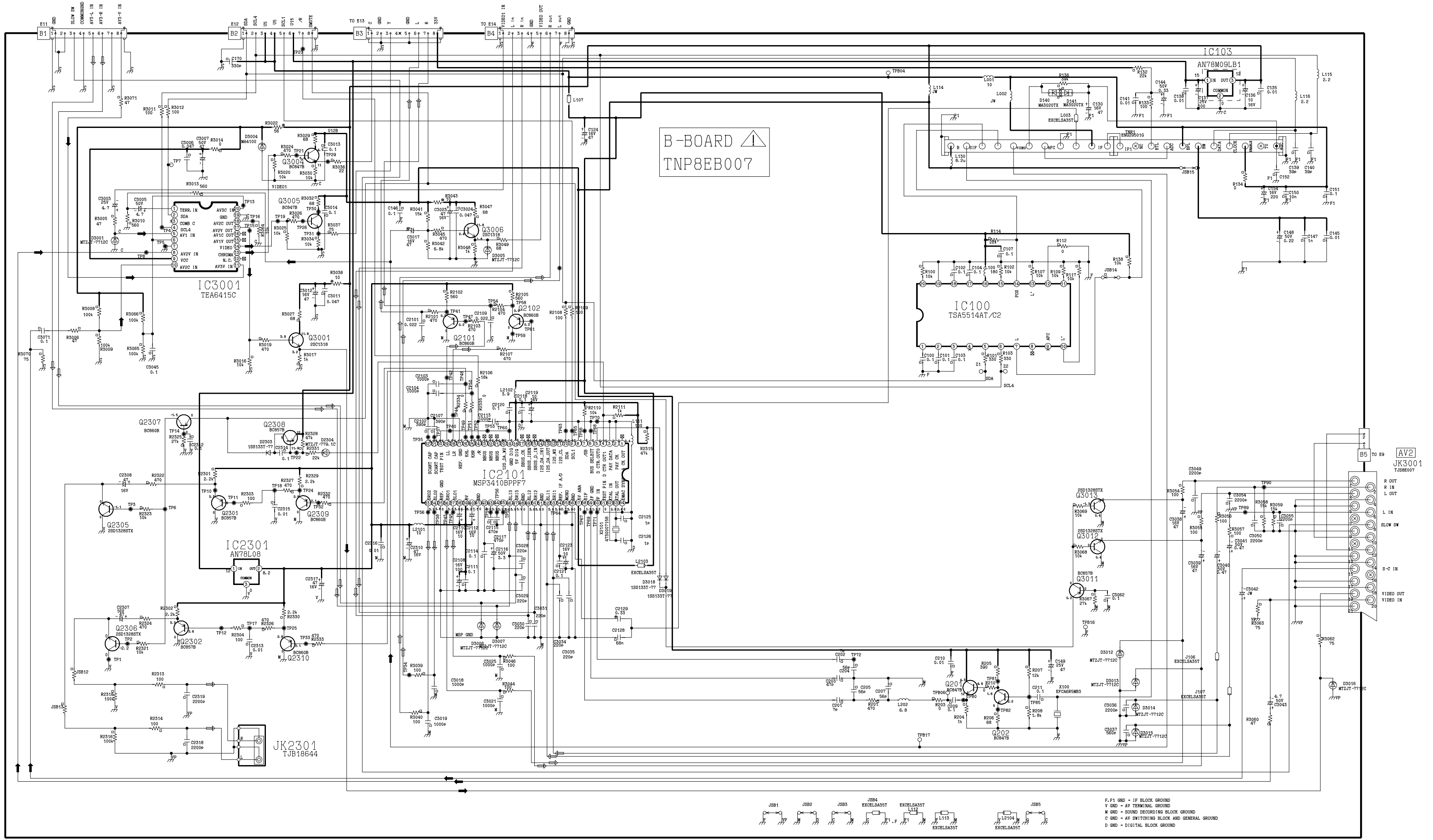

B-BBOARD  
TNP8EB007

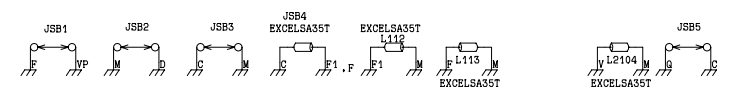

F, F1 GND - IF BLOCK GROUND  
V GND - AV TERMINAL GROUND  
M GND - SOUND DECODING BLOCK GROUND  
C GND - AV SWITCHING BLOCK AND GENERAL GROUND  
D GND - DIGITAL BLOCK GROUND

AV2  
JK3001  
TJUB8644



P-BOARD   
TNP8EP013

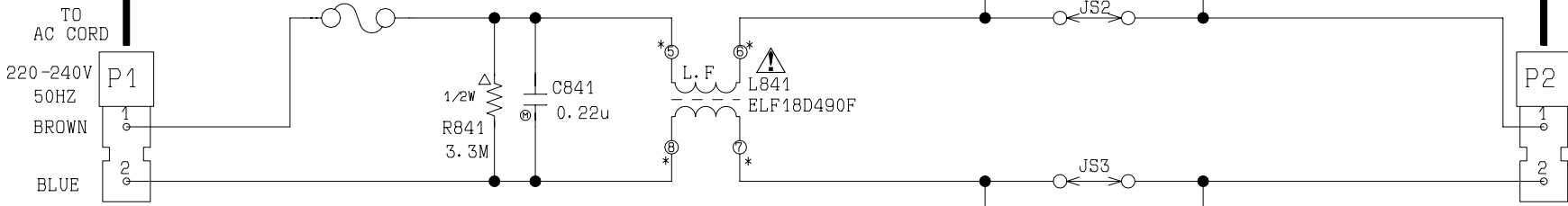

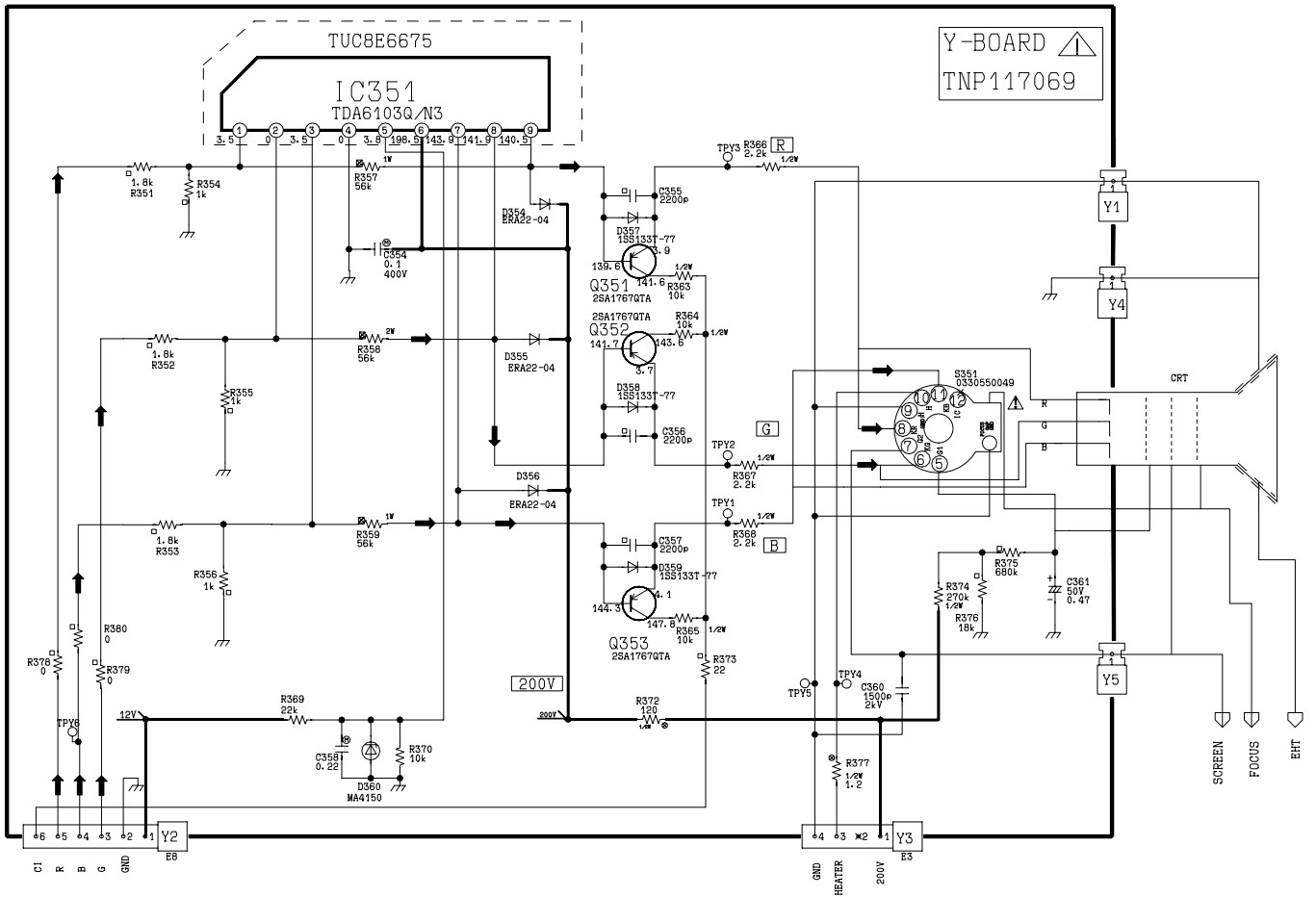

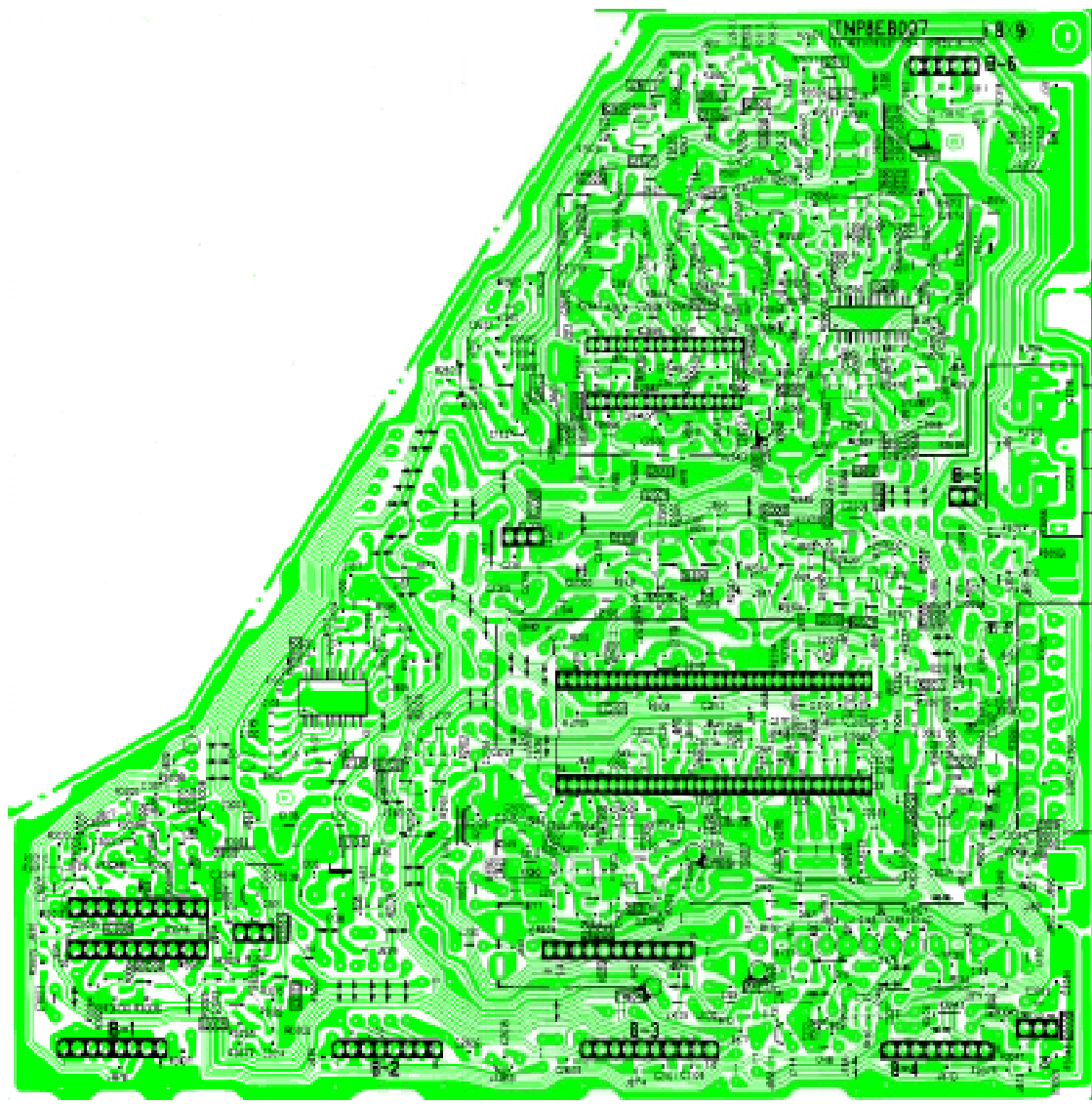

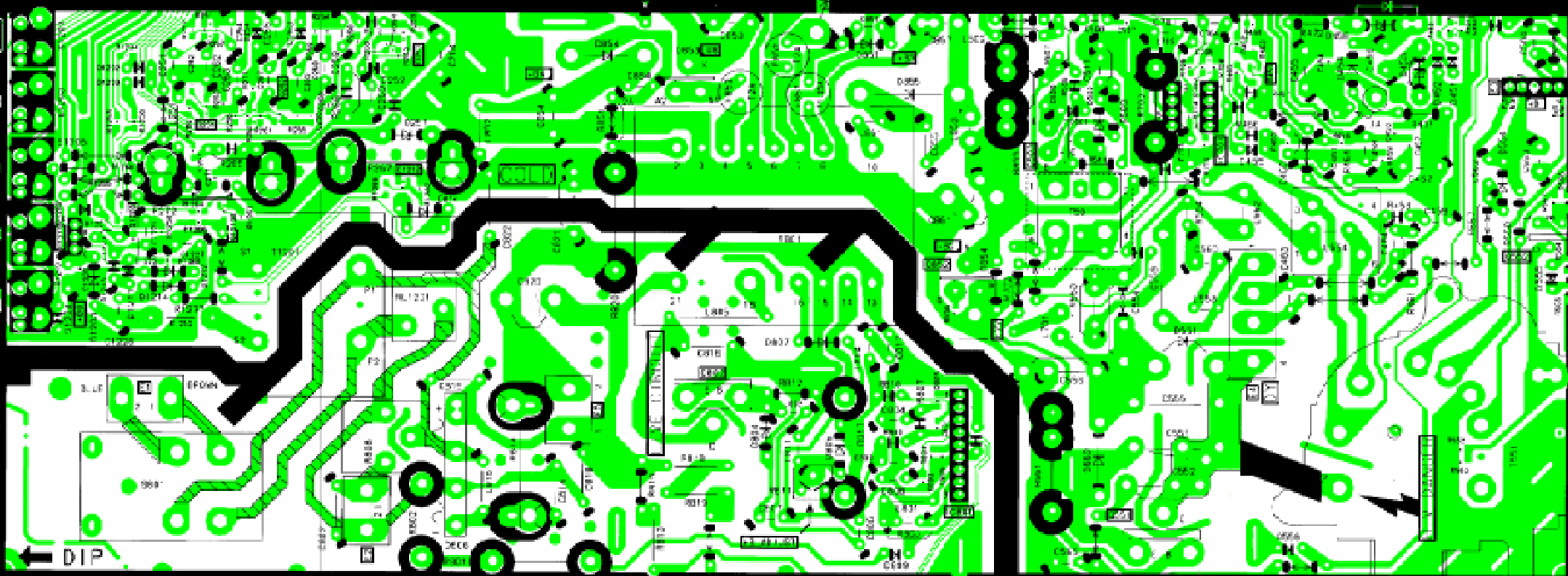
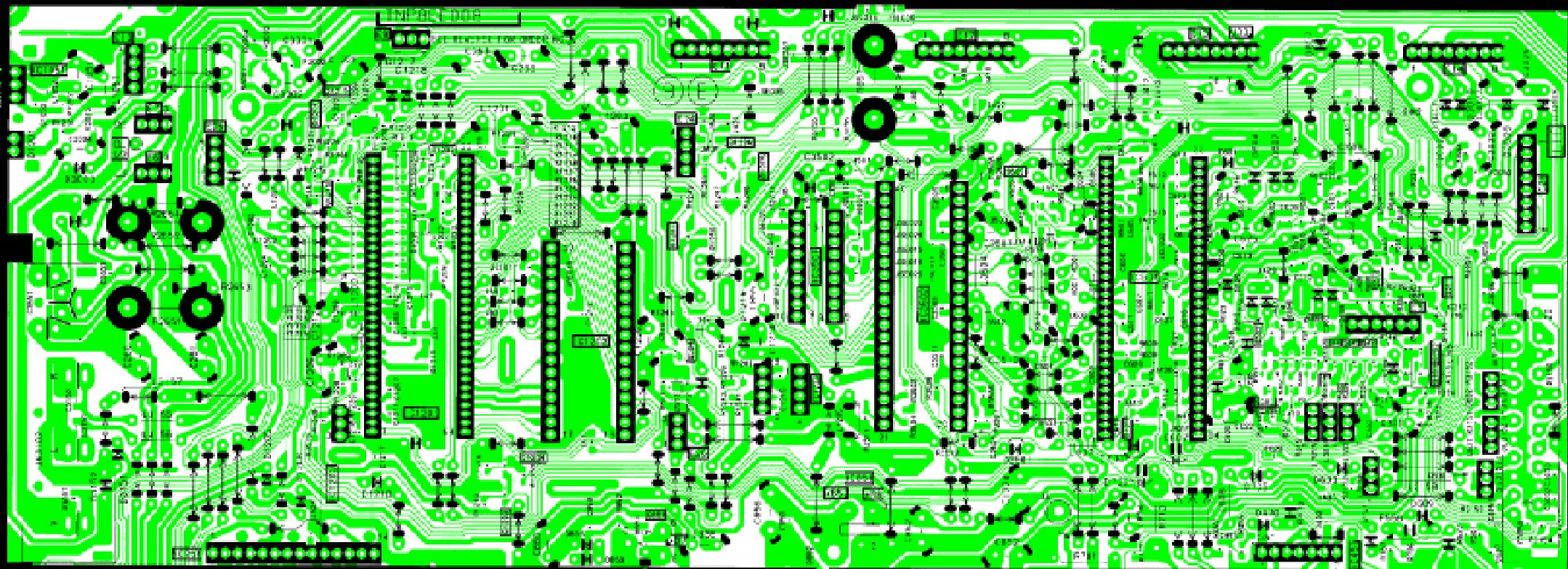



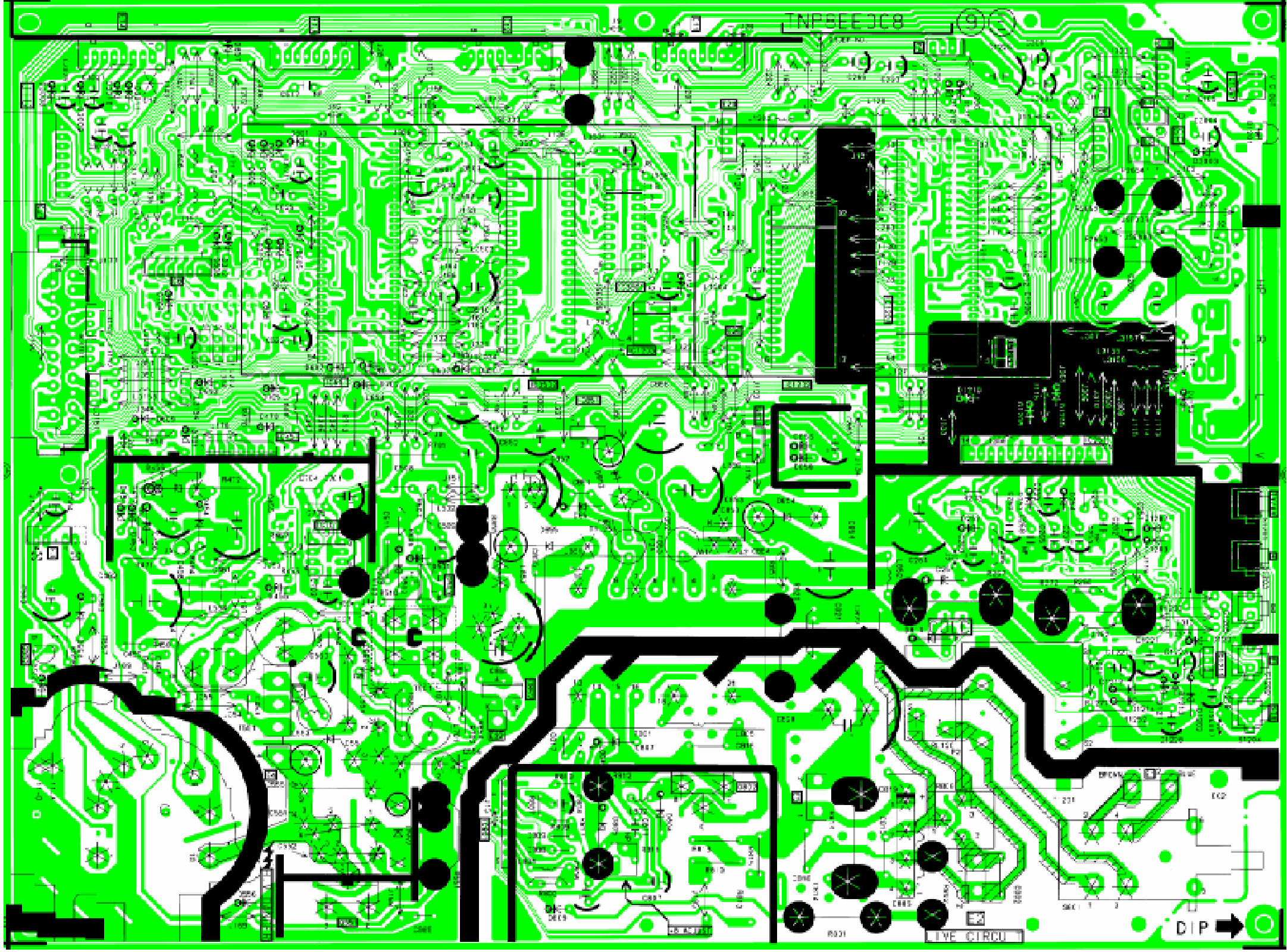

INP5LE3C8

LIVE CIRCU

DIP

R0321

204

E40

SEC 1

SEC 2

SEC 3

SEC 4

SEC 5

SEC 6

SEC 7

SEC 8

SEC 9

SEC 10

SEC 11

SEC 12

SEC 13

SEC 14

SEC 15

SEC 16

SEC 17

SEC 18

SEC 19

SEC 20

SEC 21

SEC 22

SEC 23

SEC 24

SEC 25

SEC 26

SEC 27

SEC 28

SEC 29

SEC 30

SEC 31

SEC 32

SEC 33

SEC 34

SEC 35

SEC 36

SEC 37

SEC 38

SEC 39

SEC 40

SEC 41

SEC 42

SEC 43

SEC 44

SEC 45

SEC 46

SEC 47

SEC 48

SEC 49

SEC 50

SEC 51

SEC 52

SEC 53

SEC 54

SEC 55

SEC 56

SEC 57

SEC 58

SEC 59

SEC 60

SEC 61

SEC 62

SEC 63

SEC 64

SEC 65

SEC 66

SEC 67

SEC 68

SEC 69

SEC 70

SEC 71

SEC 72

SEC 73

SEC 74

SEC 75

SEC 76

SEC 77

SEC 78

SEC 79

SEC 80

SEC 81

SEC 82

SEC 83

SEC 84

SEC 85

SEC 86

SEC 87

SEC 88

SEC 89

SEC 90

SEC 91

SEC 92

SEC 93

SEC 94

SEC 95

SEC 96

SEC 97

SEC 98

SEC 99

SEC 100

SEC 101

SEC 102

SEC 103

SEC 104

SEC 105

SEC 106

SEC 107

SEC 108

SEC 109

SEC 110

SEC 111

SEC 112

SEC 113

SEC 114

SEC 115

SEC 116

SEC 117

SEC 118

SEC 119

SEC 120

SEC 121

SEC 122

SEC 123

SEC 124

SEC 125

SEC 126

SEC 127

SEC 128

SEC 129

SEC 130

SEC 131

SEC 132

SEC 133

SEC 134

SEC 135

SEC 136

SEC 137

SEC 138

SEC 139

SEC 140

SEC 141

SEC 142

SEC 143

SEC 144

SEC 145

SEC 146

SEC 147

SEC 148

SEC 149

SEC 150

SEC 151

SEC 152

SEC 153

SEC 154

SEC 155

SEC 156

SEC 157

SEC 158

SEC 159

SEC 160

SEC 161

SEC 162

SEC 163

SEC 164

SEC 165

SEC 166

SEC 167

SEC 168

SEC 169

SEC 170

SEC 171

SEC 172

SEC 173

SEC 174

SEC 175

SEC 176

SEC 177

SEC 178

SEC 179

SEC 180

SEC 181

SEC 182

SEC 183

SEC 184

SEC 185

SEC 186

SEC 187

SEC 188

SEC 189

SEC 190

SEC 191

SEC 192

SEC 193

SEC 194

SEC 195

SEC 196

SEC 197

SEC 198

SEC 199

SEC 200

SEC 201

SEC 202

SEC 203

SEC 204

SEC 205

SEC 206

SEC 207

SEC 208

SEC 209

SEC 210

SEC 211

SEC 212

SEC 213

SEC 214

SEC 215

SEC 216

SEC 217

SEC 218

SEC 219

SEC 220

SEC 221

SEC 222

SEC 223

SEC 224

SEC 225

SEC 226

SEC 227

SEC 228

SEC 229

SEC 230

SEC 231

SEC 232

SEC 233

SEC 234

SEC 235

SEC 236

SEC 237

SEC 238

SEC 239

SEC 240

SEC 241

SEC 242

SEC 243

SEC 244

SEC 245

SEC 246

SEC 247

SEC 248

SEC 249

SEC 250

SEC 251

SEC 252

SEC 253

SEC 254

SEC 255

SEC 256

SEC 257

SEC 258

SEC 259

SEC 260

SEC 261

SEC 262

SEC 263

SEC 264

SEC 265

SEC 266

SEC 267

SEC 268

SEC 269

SEC 270

SEC 271

SEC 272

SEC 273

SEC 274

SEC 275

SEC 276

SEC 277

SEC 278

SEC 279

SEC 280

SEC 281

SEC 282

SEC 283

SEC 284

SEC 285

SEC 286

SEC 287

SEC 288

SEC 289

SEC 290

SEC 291

SEC 292

SEC 293

SEC 294

SEC 295

SEC 296

SEC 297

SEC 298

SEC 299

SEC 300

SEC 301

SEC 302

SEC 303

SEC 304

SEC 305

SEC 306

SEC 307

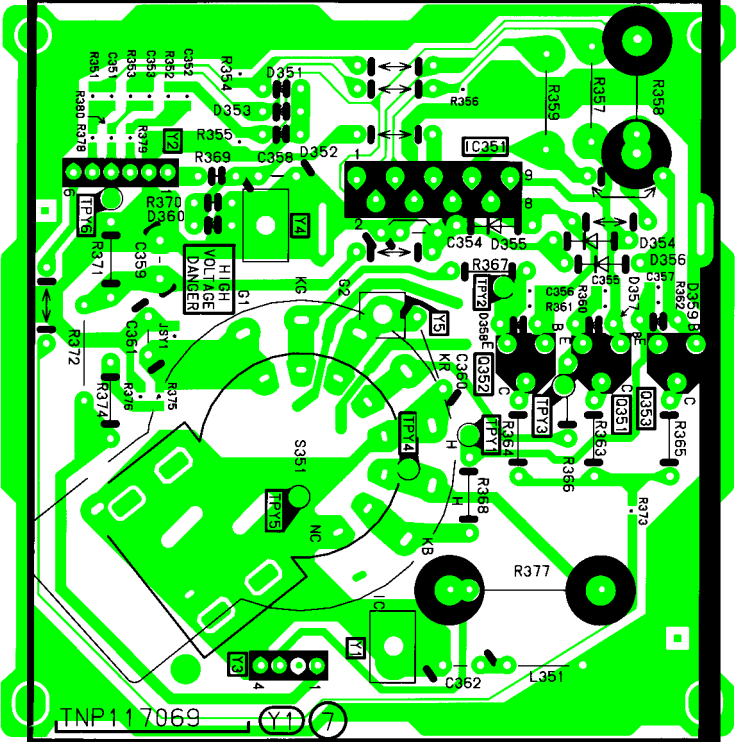

HIGH  
VOLTAGE  
DANGER

TNP117069

(Y1) 7